



Presented by



COMPETITION HANDBOOK

11-16 August 2015
Anhembi Park
São Paulo

Co-Organizer



Iniciativa da CNI - Confederação
Nacional da Indústria

Brought to you by



Iniciativa da CNI - Confederação
Nacional da Indústria

SAMSUNG Galaxy S6

O NOVO COMEÇA AGORA

Galaxy S6



Galaxy S6 edge



Design em metal e vidro com tela dual edge*



4 horas de uso com apenas 10 minutos de carga***



Câmera com maior abertura** para fotos mais vívidas



Processador de última geração

**PRODUZIDO NO
POLO INDUSTRIAL
DE MANAUS**



CONHEÇA A AMAZONIA

Imagens meramente ilustrativas. (*) Disponível apenas no Galaxy S6 Edge. (**) Em relação ao Galaxy S5. (***) Estimativa realizada em aparelho com configuração de fábrica, utilizando carregador que acompanha o produto e utilizando diversas funções, não cumulativas, de recebimento de notificação, conversação, reprodução de áudio e utilização de aplicativos. O tempo de carregamento e uso poderá variar de acordo com as condições do ambiente e da rede, bem como de acordo com as configurações do produto e dos programas, dentre outros fatores.

WELCOME

<i>Simon Bartley</i>	9
<i>Robson Braga de Andrade</i>	11
<i>Rafael Lucchesi</i>	13
<i>David Hoey</i>	14
<i>Frederico Lamego</i>	15
<i>Stefan Praschl and Michael Fung</i>	16

1. GENERAL INFORMATION

<i>1.1 Get to know São Paulo</i>	17
<i>1.2 Anhembi Park</i>	18
<i>1.3 Programme</i>	24

2. EVENTS AND IMPORTANT DATES

<i>2.1 Excursion for Technical Delegates and Experts, and Welcome Reception</i>	38
<i>2.2 Excursion for Competitors and Team Leaders including Welcome Reception</i>	40
<i>2.3 One School One Country programme</i>	41
<i>2.4 Opening and Closing Ceremonies</i>	42
<i>2.5 Farewell Party</i>	48
<i>2.6 Conference Programme</i>	48
<i>2.7 WorldSkills Village</i>	50

3. SERVICES AND FACILITIES

<i>3.1 Customer Service</i>	53
<i>3.2 Hotels</i>	54
<i>3.3 Transportation</i>	58
<i>3.4 Accreditation</i>	61
<i>3.5 Catering</i>	63
<i>3.6 Information technology - support and services</i>	67
<i>3.7 Volunteers</i>	67
<i>3.8 Press Centre</i>	68
<i>3.9 Safety and emergency procedures</i>	69
<i>3.10 Sustainability at WorldSkills São Paulo 2015</i>	73



4. WHO'S WHO?

4.1 *WorldSkills São Paulo 2015 Executive Committee* 74

4.2 *WorldSkills International Board of Directors* 75

4.3 *WorldSkills Secretariat* 76

4.4 *Participating WorldSkills Member countries and regions* 77

4.5 *Skill Management Teams* 78

5. SPECIAL THANKS

5.1 *To the Volunteers* 82

5.2 *To Partners* 84

5.3 *To WorldSkills São Paulo 2015 Sponsors and
Global Partners* 84

6. GENERAL TRAVEL INFORMATION

6. *General Travel Information* 86



Romi Industrial Complex in
Santa Bárbara d'Oeste - SP

THE BEST MACHINES IN THE LARGEST PROFESSIONAL EDUCATION EVENT IN THE WORLD.



ENGINE LATHES



CNC LATHES



TURNING
CENTERS



MACHINING
CENTERS



VERTICAL CNC
LATHES



ROMI

Official Sponsor



 www.romi.com

 [/indromi](https://www.facebook.com/indromi)

 [IndustriasRomiSA](https://www.youtube.com/IndustriasRomiSA)

 [@industriasromi](https://www.instagram.com/industriasromi)

 [@industriasromi](https://twitter.com/industriasromi)

PROUD TO BE A GLOBAL PARTNER OF THE 2015 WORLDSKILLS COMPETITION



STANLEY.



**BLACK+
DECKER**



DEWALT

"Stanley Black & Decker is proud to support WorldSkills as a Global Premium Partner. We believe the WorldSkills organization is encouraging growth in high-value vocational trades and preparing our future global workforce in a way that no other organization today is equipped to do, and we look forward to continued support of WorldSkills and its competitor teams in the future."

John F. Lundgren
Chairman and CEO
Stanley Black & Decker, Inc.

No Senac, todo aluno é ouro



Os alunos do Senac que sobem no pódio da WorldSkills são vitoriosos. Têm talento e garra para vencer.

Mas, para nós, todos os alunos do Senac valem ouro. É vencedor quem investe em educação profissional para alcançar seus sonhos. Quem estuda pelo Programa Senac de Gratuidade, aprende com a tecnologia de ponta das nossas empresas pedagógicas ou escolhe nossos cursos de educação a distância para aprimorar seus conhecimentos e conseguir seu lugar no mercado de trabalho.

Carregamos no peito mais de 58 milhões de medalhas de ouro, dos brasileiros que passaram pelo Senac nesses quase 70 anos de atuação voltada a educar para o trabalho no Setor do Comércio de Bens, Serviços e Turismo.



Senac. O ensino do futuro do mundo.

www.senac.br | facebook.com/senacbrasil | twitter.com/senacbrasil

WELCOME



SIMON BARTLEY

President WorldSkills

WorldSkills São Paulo 2015 marks a very special year for us as it is our 65th Anniversary, and I would like to reflect on how far the Competition has come in a relatively short time. From small beginnings with only 12 Competitors from just two countries in 1950 to over 1,200 Competitors from more than 60 countries and regions today.

This is our 43rd WorldSkills Competition, and it is the first time we have held our flagship event in Latin America. I would like to thank our Member organization in Brazil, SENAI, for everything they have done and continue to do to develop skills excellence.

During the event we are continuing with our Conference Programme focusing on “Inspiring Skills Excellence and Development”. Each day flows and builds on the previous topics to create a synergy like we have never experienced before. We have many partners and organizations set to engage, debate, enlighten, and stimulate participants.

To the hundreds of volunteers that are giving their time, energy, and skills to make the Competition a success, I would like to personally thank you; without you the event would not be the tremendous success that it is.

To the Experts, Delegates, and Workshop Managers and Assistants, thank you for your commitment, dedication, and your never-ending enthusiasm. You make the Competitors’ journey possible.

Finally, to the over 1,200 Competitors. You are the future of your industries, communities, countries, and the world. You join the over 14,000 WorldSkills Champions from our previous 42 Competitions.

At the end of this WorldSkills Competition, some of you will be Medallists, but you will all be Champions.

Finally, I would like to wish everyone involved in WorldSkills São Paulo 2015 good luck, my thanks, and many congratulations for a job well done!

CONSELHO NACIONAL DO SESI:

PARCEIRO NA DEFESA DO INTERESSE QUE É DE TODOS

O Conselho Nacional do Sesi, instância decisória máxima do Sesi, reúne representantes das categorias econômicas da Indústria, do Sistema Indústria, dos trabalhadores e do governo.

Como o próprio nome sugere, sua função é apontar caminhos, avaliar atividades desenvolvidas, aprovar orçamentos e contas e contribuir para que o Departamento Nacional e os Departamentos Regionais do Sesi cumpram sua missão com eficácia.

Ao desempenhar um papel de tamanha relevância e responsabilidade, o Conselho Nacional do Sesi se coloca como parceiro do Sistema Indústria, atuando em defesa dos interesses comuns que unem trabalhadores, indústria, governo e sociedade.



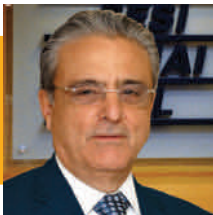

ROBSON BRAGA DE ANDRADE

*CNI President
SENAI National Council President
SESI National Department Director*

CNI, National Confederation of Industry, is honoured to welcome you to one more WorldSkills Competition, held in Latin America, for the first time. Brazil, the host country, is not only known for the strength of its internal market, but also for the strength of its industry and service networks, as well as excellent research centres and highly qualified professionals.

During WorldSkills São Paulo 2015, Brazil will welcome the best professionals competing in 50 different skills, from 63 countries in 5 continents, in order to develop and promote industry around the world.

Industry is responsible for 23.4% of the GDP and generates more than 12 million jobs in the entire country, playing a very important social and economic role in Brazil. It is the economic sector that most generates jobs and is most sought after by young people who want to begin their professional activities. Industry also pays the highest wages to its employees. São Paulo is Brazil's financial and economic capital, with 50,800 industries

CNI, an entity that promotes research, innovation and technological development for industry, believes that initiatives like WorldSkills São Paulo 2015 are excellent opportunities to invest in Brazil's vocational education system and increase competitiveness and labour qualification in Brazil, as well as boost sustainable development and create a positive business environment.

We are the seventh largest economy in the world, with a huge and varied industrial park, ranging from the production of consumer goods to cutting-edge technology, but we still have progress to be made and lots to learn about regarding vocational education, with a promising future ahead. Improving competitiveness is essential to continue promoting sustainable growth.

CNI, SENAI and WorldSkills International, have decided to join forces to make this Competition a success, which will bring an immeasurable legacy to the Brazilian and global industry. Without the effort, support and dedication from each Delegation and everyone involved in this great event promoting education and progress for the Brazilian industry, none of this would be possible.

As the largest Brazilian industry entity – with almost 700,000 companies- we hope that all WorldSkills São Paulo 2015 visitors and participants have a wonderful Competition, filled with learning, new experiences and productive exchanges.

EDUCAÇÃO EMPREENDEDORA SEBRAE

CONHEÇA AS SOLUÇÕES DO PROGRAMA NACIONAL DE EDUCAÇÃO EMPREENDEDORA DO SEBRAE:

ENSINO FUNDAMENTAL

JOVENS EMPREENDEDORES PRIMEIROS PASSOS (JEPP)

A partir de histórias, instiga os estudantes a desenvolver o comportamento empreendedor e a vivenciar as etapas de um plano de negócios.

ENSINO MÉDIO

DESPERTAR

Aborda uma visão ampla do empreendedorismo, incentivando a cooperação, a cidadania e a ética.

FORMAÇÃO DE JOVENS EMPREENDEDORES (FJE)

Estimula o comportamento empreendedor, instigando o protagonismo juvenil e preparando os estudantes para o mundo do trabalho.

CRESCENDO E EMPREENDENDO

Apresenta o universo do empreendedorismo por meio de encontros vivenciais e orienta a identificação de oportunidades.

ENSINO TÉCNICO E PROFISSIONAL

PRONATEC EMPREENDEDOR

Apresenta o empreendedorismo como possibilidade de inserção profissional no mundo do trabalho.

ENSINO SUPERIOR

DESAFIO UNIVERSITÁRIO EMPREENDEDOR (DUE)

Uma abordagem inovadora que utiliza a competição para falar de empreendedorismo aos estudantes universitários através de jogos on-line e simuladores de empresa.

DISCIPLINA DE EMPREENDEDORISMO

Estimula o comportamento de quem faz acontecer, busca oportunidades e desenvolve ações voltadas a resultados.

EMPREENDEDORISMO EM DOIS TEMPOS

Sensibiliza os estudantes quanto ao empreendedorismo social, empresarial e corporativo.

MEET THE SOLUTIONS OF SEBRAE NATIONAL ENTREPRENEURIAL EDUCATION PROGRAM

ELEMENTARY SCHOOL

Young Entrepreneurs First Steps (JEPP) – Using stories, urges students to develop entrepreneurial behavior and to experience the stages of a business plan.

HIGH SCHOOL

Awaking to Entrepreneurship Program – It addresses a broad vision of entrepreneurship by encouraging cooperation, citizenship and ethics.

Training of Young Entrepreneurs (FJE) – It encourages entrepreneurial behavior, urging youth participation and preparing students for the world of work.

Growing and Undertaking – It presents the world of entrepreneurship through experiential meetings and guides the identification of opportunities.

TECHNICAL AND PROFESSIONAL EDUCATION

Pronatec Entrepreneur – It presents entrepreneurship as a possibility of professional integration in the labor market.

HIGHER EDUCATION

University Entrepreneur Challenge (DUE) – An innovative approach that uses the competition to speak of entrepreneurship to college students through online games and business simulations.

Discipline of Entrepreneurship – It stimulates the behavior of those who makes it happen, seeks opportunities and develops actions to results.

Entrepreneurship in Two Steps – It sensitizes students about the social, business and corporate entrepreneurship.





RAFAEL LUCCHESI

*General Director at the National Department in SENAI
Education and Technology Director at CNI
Director Superintendent at SESI National Department*

Welcome to WorldSkills São Paulo 2015! I am pleased to welcome you all to our city for the 43rd WorldSkills Competition, the greatest vocational education and skills excellence Competition in the world, WorldSkills Competition, hosted in Latin America for the first time.

The National Service for Industrial learning – SENAI, one of the five greatest professional education complexes in the world and the largest in Latin America, has been working for over 70 years to enhance the quality of vocational education in Brazil according to the country's industrial needs, by investing in training and professional competitiveness, and providing 150,000 opportunities for technical courses every year.

According to recent research, 72% of professionals who have completed technical courses are employed in the next year after graduating. Among the economic sectors in the country, industry pays the highest salaries to its employees.

Vocational education provides various opportunities and possibilities for young professionals and has a very important role in building and promoting citizenship. As a result, professionals that are more qualified and specialized provide significant improvements for the country as a whole, in regards to employability, competitiveness, productivity, and sustainable development. In Brazil, there are 249 technical schools in various States and regions.

I would like to thank SENAI, WorldSkills International, and everyone else who has contributed to the success of WorldSkills São Paulo 2015.

Together, we'll present inspirational and success stories that will help young people and adults as they choose their professional training options as an important foundation for a promising future.



DAVID HOEY
CEO WorldSkills International

Welcome to WorldSkills São Paulo 2015, our 43rd WorldSkills Competition! It is very exciting to have the Competition in Latin America for the first time. Brazil is the seventh largest economy in the world with a very exciting future.

Our vision relies on contributions from dedicated teachers and leaders in vocational education and training, industry mentors, and from decision makers.

The WorldSkills global network is a hub for developing vocational education and training.

Quality training outcomes create opportunities for young people – opportunities that bring recognition and status, and ensure skills development aligns with workplace demands.

The experiences and dreams of the WorldSkills Competitors make powerful stories that inspire others to choose skills education as the foundation for a fulfilling future.

The WorldSkills São Paulo 2015 team, WorldSkills staff, and Members have collaborated closely and worked tirelessly to plan and deliver this Competition. Not only will this Competition be the biggest ever, but also we have incorporated the best ideas and experiences from previous events and added innovative new ideas to ensure this is the greatest showcase of skills excellence in the world!

Organizing an event on this scale is not easy and I wish to thank every person, company, institute, and government who has contributed. A very special thank you to SENAI and CNI in Brazil.

I am looking forward to seeing over 200,000 visitors come through the doors and experience WorldSkills Competition like never before. But just as important, people around the world will also be able to experience the Competition through virtual tours and information.

I wish you an enjoyable, exciting, stimulating, and inspiring WorldSkills experience. Let the show begin!



STEFAN PRASCHL
Chair of the Technical Committee



MICHAEL FUNG
Vice Chair of the Technical Committee

On behalf of the Technical Committee, we welcome all participants to the 43rd WorldSkills Competition. This is the first time WorldSkills has been held in Brazil, known for happy people, sun, beaches, and football. More importantly, Brazil is the seventh largest economy in the world with a huge demand for skilled workers.

For the first time, there will be more than 1,200 Competitors from more than 60 countries and regions. To organize such a huge Competition, even for Brazil, is a big challenge. However, the WorldSkills São Paulo 2015 Competition Organizer has faced this challenge and has done their utmost to setup a Competition environment of the highest industry standard and quality.

All this is done to ensure that Competitors have an equal and fair chance to showcase their excellence. Yes, it will be a Competition for medals, but it will be more than that - it will be a chance for Competitors, Experts, and all Delegates to share their experience and knowledge as well as make friends from all over the world.

Finally, we wish to thank the WorldSkills São Paulo 2015, Technical Coordination, and their outstanding team for preparing the competitions in São Paulo.

Together, let us focus all our efforts to make the 43rd WorldSkills Competition the best Competition ever, and to further raise the standard for WorldSkills Abu Dhabi 2017.

Sincere thanks on behalf of WorldSkills International to all Technical Delegates who act as Jury Presidents, and a special thanks to our colleagues acting as Jury President Team Leaders.

We are proud of our Competitors, so let's make this Competition a once-in-lifetime experience for them.

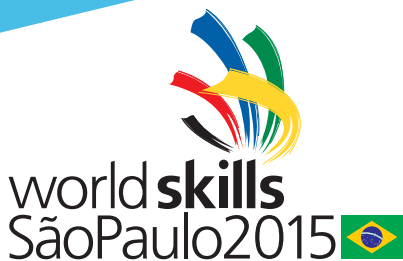

Sponsored by:



Planejar
com experiência
Plan with experience

Executar
com imaginação
Execute with imagination

Montadora oficial e exclusiva da:
The official and exclusive stand contractor for:

WorldSkills São Paulo 2015

www.dmdl.com.br



DMDL

GESTÃO E SOLUÇÕES TÉCNICAS
INTEGRADAS PARA EVENTOS

TECHNICAL MANAGEMENT AND INTEGRATED
SOLUTIONS FOR EVENT AND EXHIBITIONS

1. GENERAL INFORMATION

1.1 Get to know São Paulo

The city is located in the southeast region of Brazil and has 11.8 million inhabitants (IBGE, 2014).

Last year, São Paulo welcomed 15.08 million visitors, and 51% of these people were in the city mainly for business purposes.

Essential to business in the entire country, São Paulo is the financial and economic capital of Brazil, not only due to its market, but also because of the large service network, the best research and study centres, and the most skilled professionals.

In addition, it has a variety of culinary options, including international cuisine, with 15,000 restaurants and 20,000 bars.

Education and communication: São Paulo has 249 technical schools, 29 universities, 7,023 elementary and basic education institutions of the Latin American Information Technology centre, the largest circulation national newspapers, 607 magazines, 42 radio stations, 11 TV stations, and 6 cable TV providers.

Industry, economy and finances: São Paulo is home to 50,800 industries, 38 of the 100 largest private national capital companies, 63% of the international groups located in Brazil, 1,900 bank branches belonging to 17 of the 20 largest banks, 40 international chambers of commerce and business, and the largest stock exchange in South America.

Services and infrastructure: The city offers more than 400 hotels with approximately 42,000 rooms available for booking, 576 travel agencies, about 86,000 rental cars, 34,000 taxis, 15,000 urban buses, the largest fleet of helicopters in the world (411), 49 airlines in operation, 2,500 health service facilities, and 45,000 military and civil policemen.

Culture, commerce, leisure, and entertainment: This bustling metropolis features 282 cinemas, 164 theatres, 39 cultural centres, 146 libraries, 53 shopping malls, 240,000 stores, 103 parks and green spaces, 11 show venues with more than 300 seats, 10 football stadiums, plus other facilities that make the city even more prepared to receive a variety of audiences.

São Paulo, an iconic city, stands out for its innovative and creative characteristics. It is also a contrasting environment, made up of "concrete jungles" with large buildings and plenty of green nature spaces – with 300,000 km² of vegetation.

Each region in this cosmopolitan city has its own unique identity.

We hope you enjoy it and feel welcome!

1.2 Anhembi Park

*WorldSkills São Paulo 2015 will occupy the entire Anhembi Park, the largest exhibition centre in Latin America with a total 400,000 m², with **213,000 m²** used for the **Competition**, including the **Samsung Pavilion, Sambadrome, and Convention Palace**. This will be the first time in Anhembi's history, that a single event occupies all three areas at the same time.*

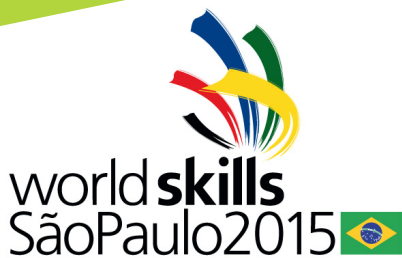

Sponsored by



American Welding Society®



ANHEMBI PARK



Presented by

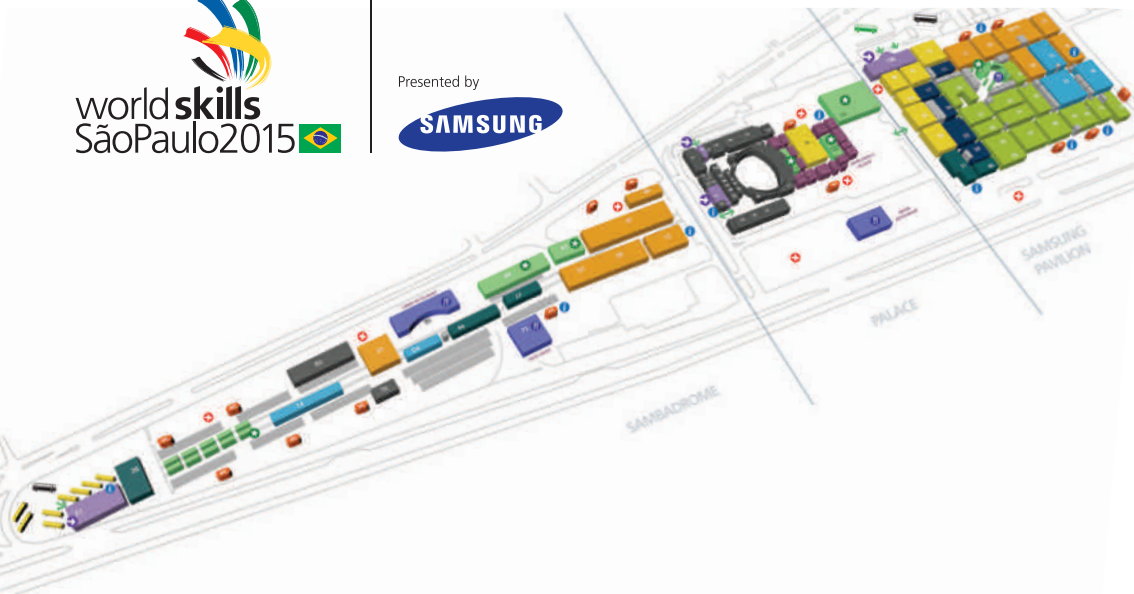

SECTORS

- Information and Communication Technology
- Creative Arts and Fashion
- Construction and Building Technology
- Transport and Logistics
- Manufacturing and Engineering Technology
- Social and Personal Services

LEGEND

- Accreditation
- Bus Station
- Entrance
- Free Transportation
- Highlights
- Information
- Medical Station
- Restaurants / Food Court
- WC
- Sponsors
- WorldSkills Village



OVERVIEW

Sambadrome

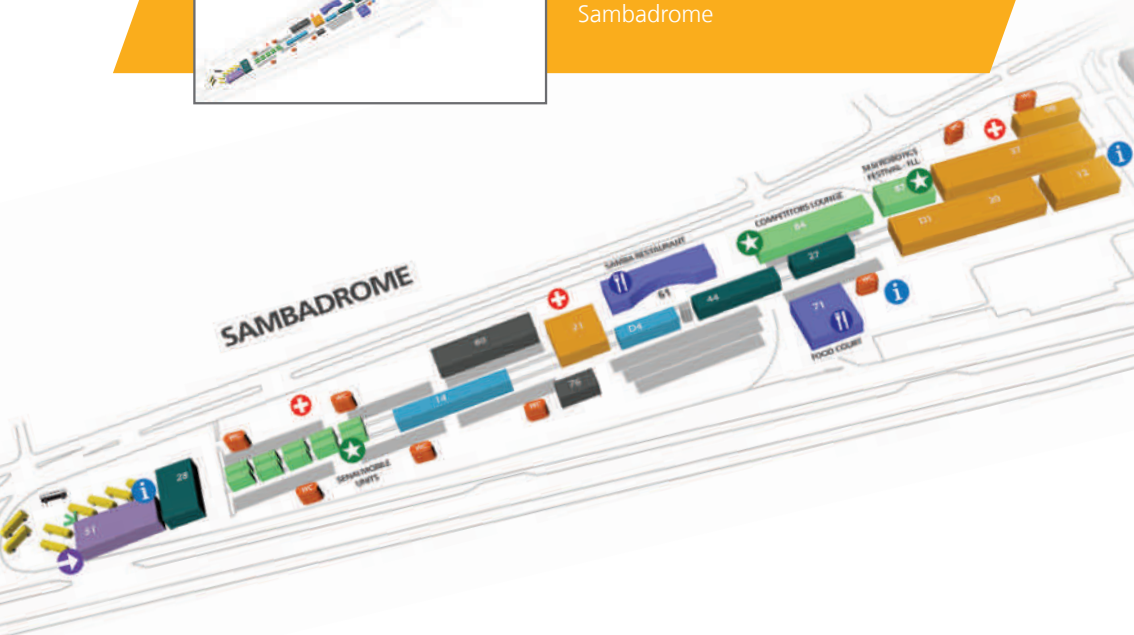

SAMBADROME

Construction and Building Technology

- 8 Architectural Stonemasonry
- 12 Wall and Floor Tiling
- 20 Bricklaying
- 21 Plastering and Drywall Systems
- 37 Landscape Gardening
- D1 Concrete Construction Work

Transport and Logistics

- 14 Aircraft Maintenance
- D4 Heavy Vehicle Maintenance

Creative Arts and Fashion

- 27 Jewellery
- 28 Floristry
- 44 Visual Merchandising and Window Dressing

Special Areas

- ➔ 51 Reception
- 60 Volunteering
- 🚪 61 Samba Restaurant
- ★ 64 Competitors Lounge
- ★ 67 SESI-FLL Robotic Festival
- 🚪 71 Food Court
- 76 Sustainability
- ★ SENAI Mobile Units



OVERVIEW Palace

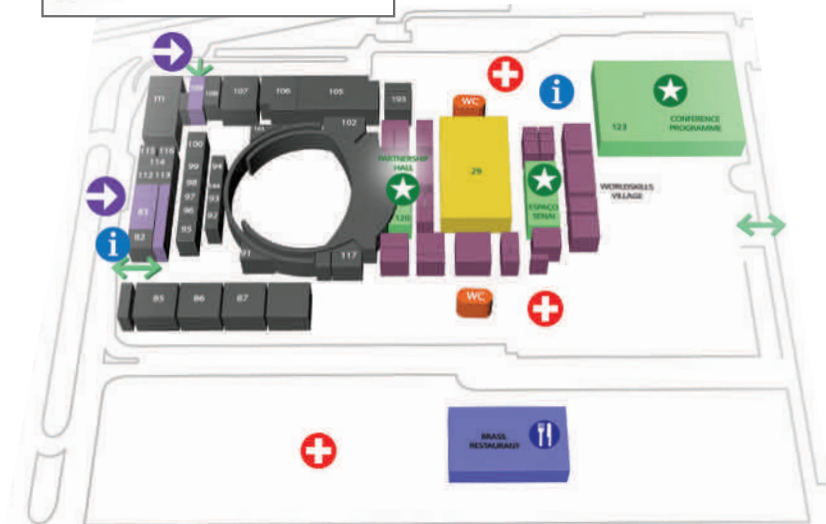

PALACE

Social and Personal Services

29 Hairdressing

Palace Areas

- 82 - Information Centre
- ➔ 83 Accreditation (Press / Conference)
- 85 Press Centre
- 86 WorldSkills MarCom and Official Photography
- 87 WSTV
- 91 WorldSkills MarCom Storage
- 92 WSI Sponsorship and Partnership Office
- 93 WSSP 2015 Sponsorship Office
- 94 WorldSkills Foundation
- 95 Press Briefing Room
- 97 WSI CEO
- 98 WSSP2015 Executive Committee
- 99 SENAI Directors Office
- 100 VIP Authorities Room
- 101 WorldSkills São Paulo 2015 Events Office
- 102 WorldSkills Abu Dhabi 2017
- 105 CNI President
- 106 Government and Ministries VIP Lounge
- 107 Conference Auditorium 8
- 108 Luggage Room
- ➔ 109 VIP Accreditation
- 111 Conference Auditorium 9
- 112 Customer Service
- 113 WSI Member Support
- 114 Meeting Room 1
- 115 Meeting Room 2
- 116 Meeting Room 3
- 117 Meeting Room 4
- ★ 120 Partnership Hall
- ★ 123 Conference Programme
- 194 SENAI Executive Office
- 🍴 Brasil Restaurant
- ★ Espaço SENAI



OVERVIEW

Samsung Pavilion



SAMSUNG PAVILION

Manufacturing and Engineering Technology

- 1 Polymechanics and Automation
- 3 Manufacturing Team Challenge
- 4 Mechatronics
- 5 Mechanical Engineering Design – CAD
- 6 CNC Turning
- 7 CNC Milling
- 10 Welding
- 16 Electronics
- 19 Industrial Control
- 23 Mobile Robotics
- 42 Construction Metal Work
- 43 Plastic Die Engineering
- 45 Prototype Modelling
- 46 Sheet Metal Technology
- D3 Industrial Mechanics Millwright

Creative Arts and Fashion

- 31 Fashion Technology
- 40 Graphic Design Technology

Information and Communication Technology

- 2 Information Network Cabling
- 9 IT Software Solutions for Business
- 11 Print Media Technology
- 17 Web Design
- 39 IT Network Systems Administration

Construction and Building Technology

- 15 Plumbing and Heating
- 18 Electrical Installations
- 22 Painting and Decorating
- 24 Cabinetmaking
- 25 Joinery
- 26 Carpentry
- 38 Refrigerating and Air Conditioning

Transport and Logistics

- 13 Autobody Repair
- 33 Automobile Technology
- 36 Car Painting

Social and Personal Services

- 30 Beauty Therapy
- 32 Pâtisserie and Confectionery
- 34 Cooking
- 35 Restaurant Service
- 41 Health and Social Care
- D2 Bakery

Special Areas

- ➔ 138 Accreditation
- ★ 175 Cyber
- ⓘ Cyber Food Court

1.3 PROGRAMME

To provide consistency across all documentation from year to year, abbreviations are used to indicate days before, during and after the Competition. For example "C1" is Competition day 1, "C-1" is one day before Competition day 1 and "C+1" is one day after the last day of the Competition.

C-7	C-6	C-5	C-4	C-3	C-2	C-1	C1	C2	C3	C4	C+1	C+2	
05.08.15	06.08.15	07.08.15	08.08.15	09.08.15	10.08.15	11.08.15	12.08.15	13.08.15	14.08.15	15.08.15	16.08.15	17.08.15	
Wednesday	Thursday	Friday	Saturday	Sunday	Monday	Tuesday	Wednesday	Thursday	Friday	Saturday	Sunday	Monday	
Arrival TD, TDA, CE, DCE	Arrival E, I, TO		Arrival OD, C, TL, O, OO			Opening Ceremony	Day 1	Day 2	Day 3	Day 4	Closing Ceremony	Departures	
Preparation							Competition						Post Competition

WorldSkills São Paulo 2015
(event dates as advertised to the public)

See page 37 for legend of abbreviations.

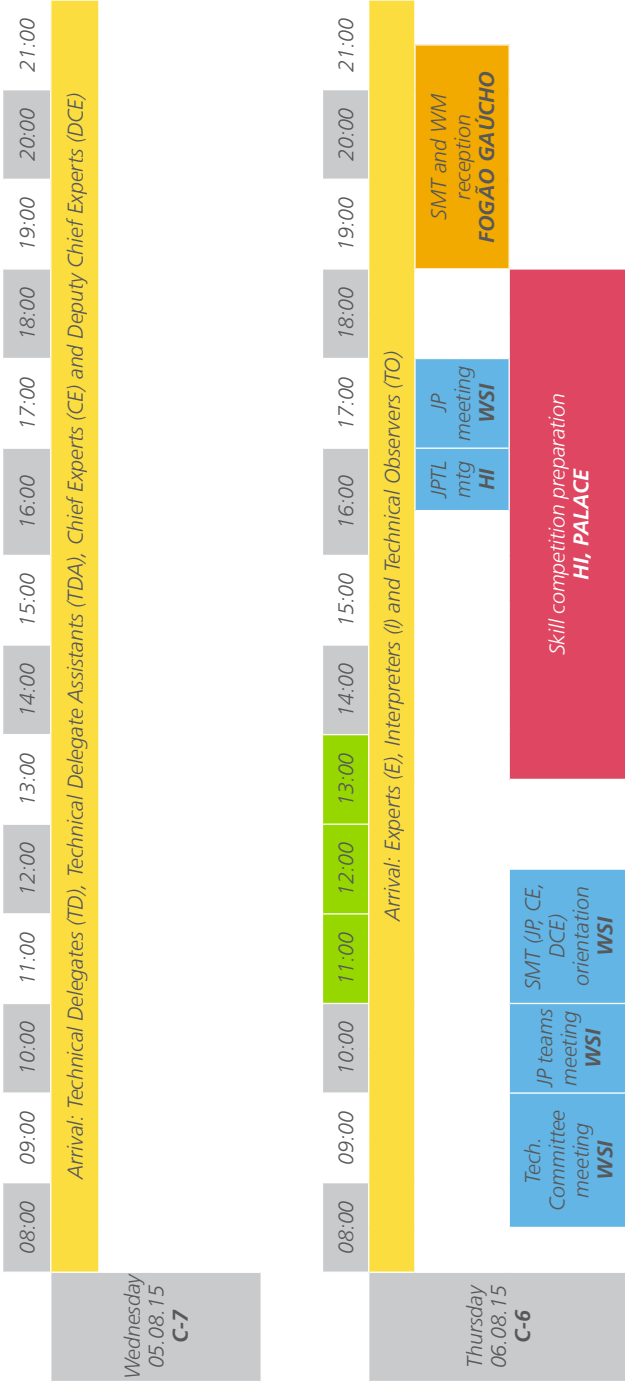

Lunch is served only at the Brasil restaurant.

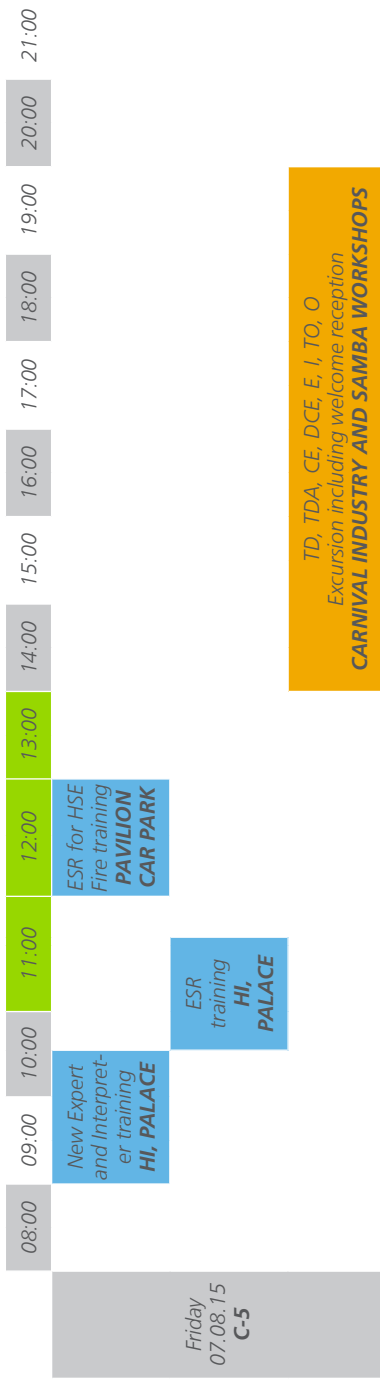

There is no access to Competition halls or workshops. Experts and Interpreters will not get access to rooms unless they are attending the training sessions.

Lunch is served only at the Brasil restaurant.

Excursion departs from Competition site – assemble at 14:00 at the Pavilion bus station. Transfer back to hotels.

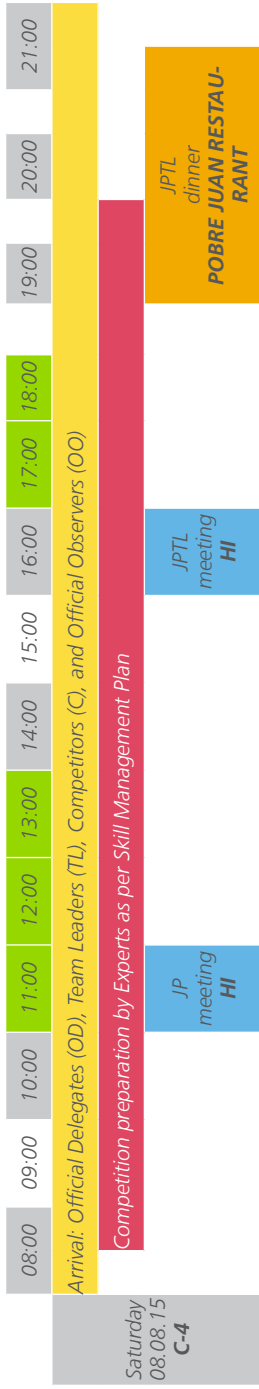

Site operational for accredited persons. Competitors and Team Leaders have no access to the Sambadrome, Palace, or Pavilion.

Lunch at the Samba and Brasil restaurants, dinner served at the Brasil restaurant.

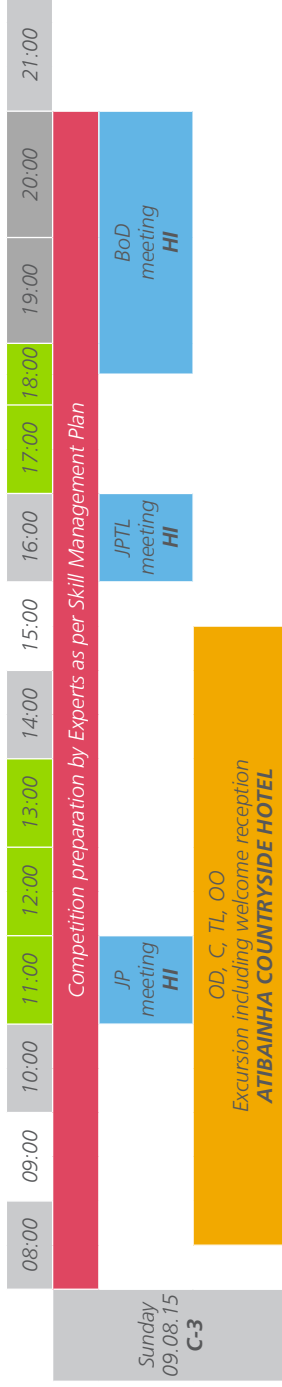

Site operational for accredited persons. Competitors and Team Leaders have no access to the Sambadrome, Palace, or Pavilion.

Lunch at Samba and Brasil restaurants, except excursion participants who will have lunch during the excursion. Dinner served at the Brasil restaurant.

Excursion departure from the hotels at 08:30, departure from Atibainha Hotel from 15:30. Competitors not staying at the Holiday Inn dine in their respective hotels.



Press Centre opening hours: 12:00-20:00.

Lunch is served at the Samba and Brasil restaurants. Experts and Competitors scheduled for lunch as per the Skill Management Plan.

Final inspection (including HSE) of workshops.

Dinner for Competitors and Team Leaders is served at the Brasil restaurant.

WorldSkills Champions Night open to Competitors of previous Competitions 20:00-23:00. RSVP to alex.musial@worldskills.org.

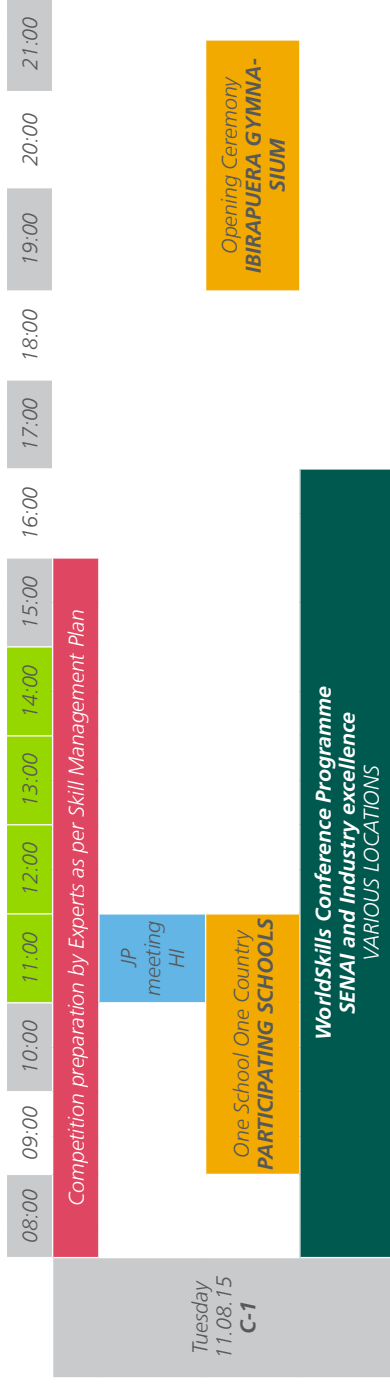

Press Centre opening hours: 08:00-02:00 next morning.

WorldSkills Conference Programme – ticket only.

Familiarization continues for CNC Milling, CNC Turning, and Floristry.

Please note that One School One Country is for Competitors, Team Leaders, Official Delegates, and Technical Delegates only.

Lunch is served at the Samba and Brasil restaurants.

Departure for the Opening Ceremony from hotels at 16:00, with a meal being served on the buses for Competitors and Team Leaders.



Press Centre opening hours: 08:00-20:00.

Press welcome briefing: 09:00 in the Press Briefing room.

Partnership Hall opening hours: 09:00-18:00.

WorldSkills Conference Programme – ticket only.

Lunch is served at the Samba and Brasil restaurants. Experts and Competitors scheduled for lunch as per the Skill Management Plan.

Dinner for Competitors and Team Leaders is served at the Brasil restaurant.

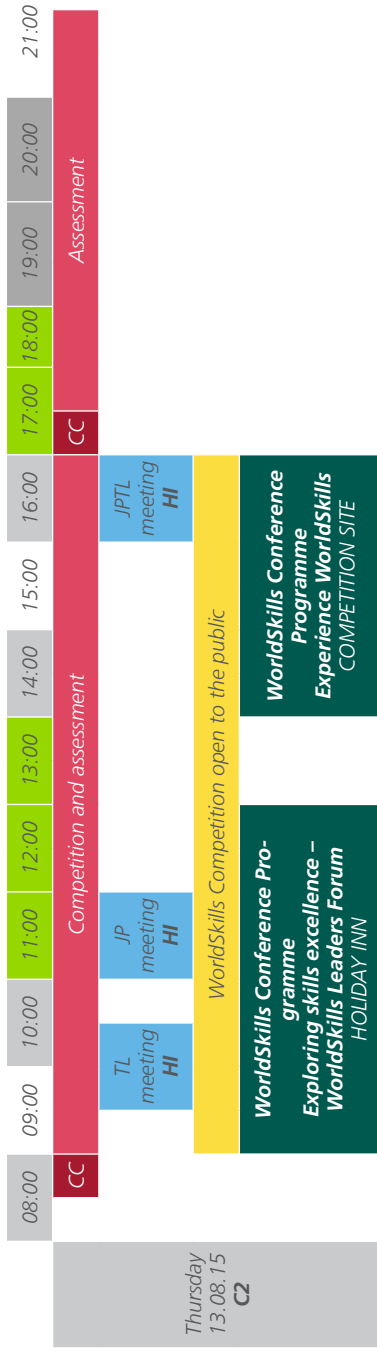

Press Centre opening hours: 08:00-20:00.

Daily press briefing: 08:30 in the Press Briefing room.

Partnership Hall opening hours 09:00-19:00.

WorldSkills Conference Programme – ticket only.

Lunch is served at the Samba and Brasil restaurants. Experts and Competitors scheduled for lunch as per the Skill Management Plan.

Dinner for Competitors and Team Leaders is served at the Brasil restaurant.

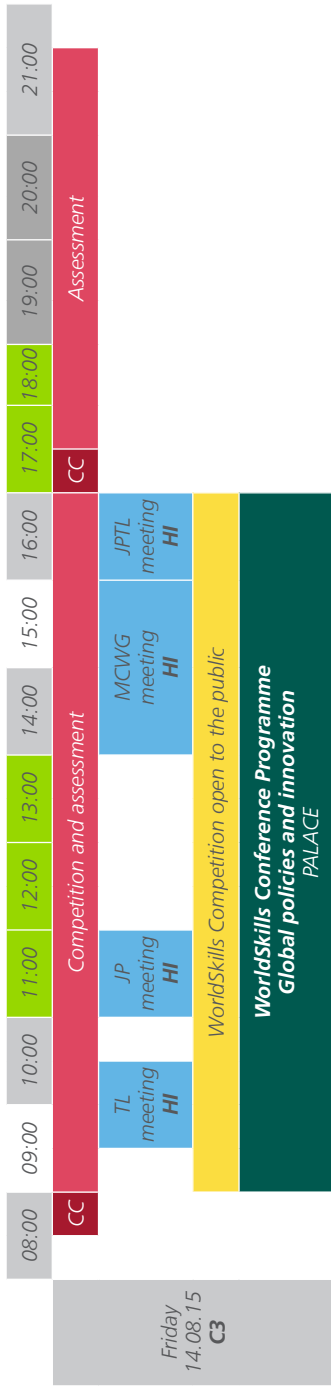

Press Centre opening hours: 08:00–20:00.

Daily press briefing: 08:30 in the Press Briefing room.

Partnership Hall opening hours: 09:00-19:00.

WorldSkills Conference Programme – ticket only.

Lunch is served at the Samba and Brasil restaurants. Experts and Competitors scheduled for lunch as per the Skill Management Plan.

Dinner for Competitors and Team Leaders is served at the Brasil restaurant.

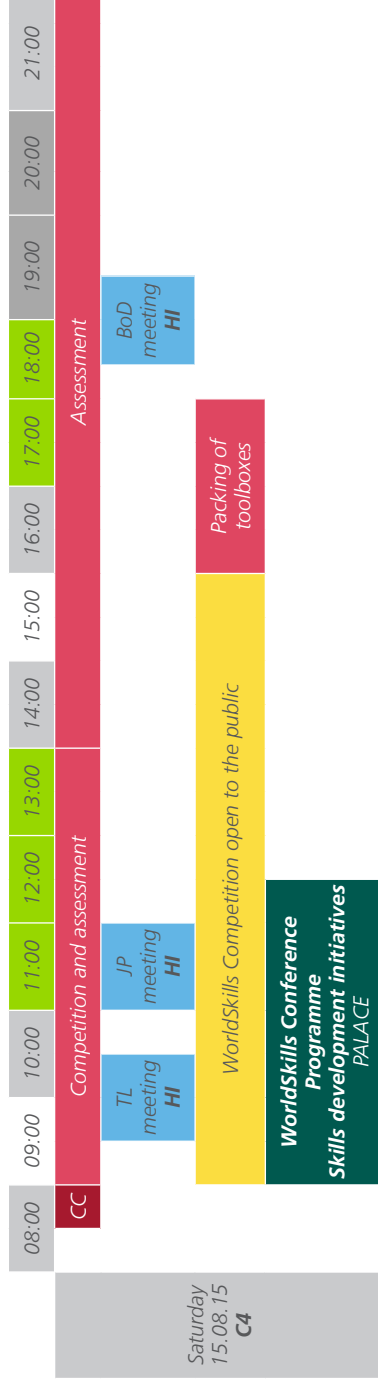

Press Centre opening hours: 08:00-20:00.

Daily press briefing: 08:30 in the Press Briefing room.

Partnership Hall opening hours: 09:00-19:00.

WorldSkills Conference Programme – ticket only.

Lunch is served at the Samba and Brasil restaurants. Experts and Competitors scheduled for lunch as per the Skill Management Plan.

Dinner is served at the Samba and Brasil restaurants.

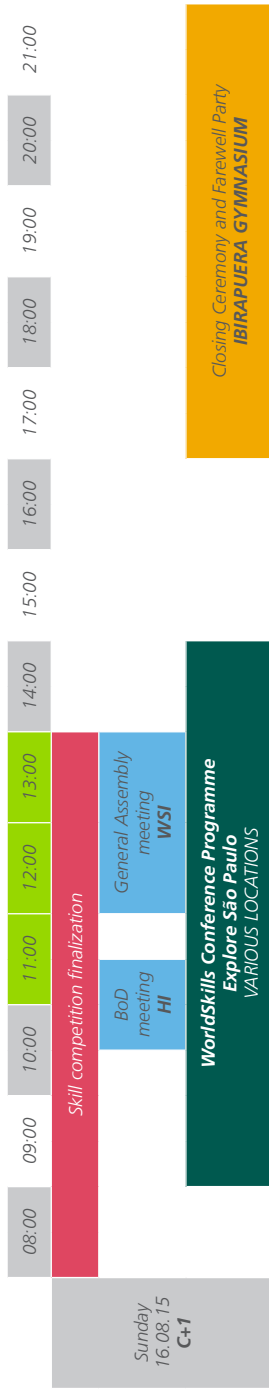

Press Centre opening hours: 08:00-03:00 next morning.

CIS closes at 10:00.

WorldSkills Conference Programme – ticket only.

Press briefing on Ceremony, tickets, and results: 12:00 in the Press Centre.

Lunch is served only at the Brasil restaurant.

Departure for the Closing Ceremony from the hotels at 15:30 with a meal being served on the buses for Competitors and Team Leaders.

Closing Ceremony is 17:00-20:00

Farewell Party is from 20:00-22:00.

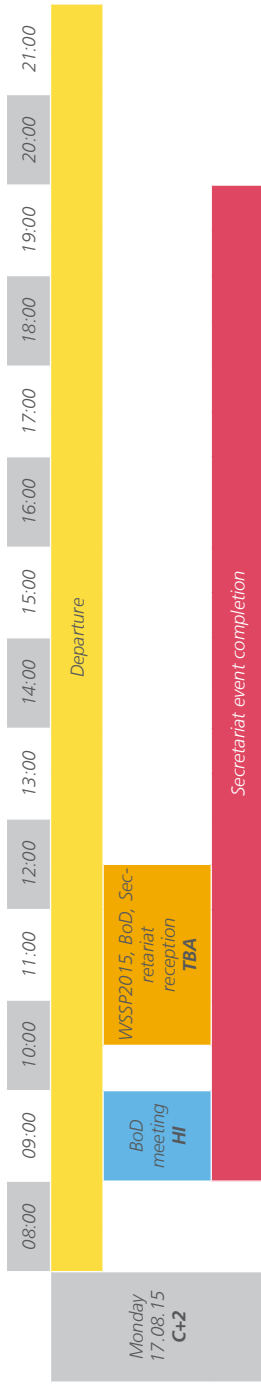

Press Centre opening hours: 08:00-14:00.

Abbreviations

WORLD SKILLS POSITIONS AND NAMES	
BoD	Board of Directors
C	Competitors
CC	Competitor communication
CE	Chief Expert
CIS	Competition Information System
DCE	Deputy Chief Expert
E	Expert
ESR	Expert with Special Responsibilities
JP	Jury President

JPTL	Jury President Team Leader
MCWIG	Marketing and Communication Working Group
O	Observer
OD	Official Delegate
OO	Official Observer
SMT	Skill Management Team
TD	Technical Delegate
TDA	Technical Delegate Assistant
TL	Team Leader
TO	Technical Observer (Workshop Manager from WorldSkills Abu Dhabi 2017)

VENUES	
WSI	WorldSkills Meeting Room in the Holiday Inn
HI	Holiday Inn
IG	Ibirapuera Gymnasium

Time Key

MEAL TIMES
SKILL OUT TIMES

2. EVENTS AND IMPORTANT DATES

2.1 Excursion for Technical Delegates and Experts, and Welcome Reception:

Friday, 7 August 2015 (C-5)

Who will participate?

Technical Delegates, Technical Delegate Assistants, Chief Experts, Deputy Chief Experts, Experts, Interpreters, Technical Observers, and Observers.

Excursion description: WorldSkills São Paulo 2015 would like to invite all of the Experts and Technical Delegates to experience a bit of authentic Brazilian culture at a workshop about the Carnival industry, held in one of the most traditional samba schools in São Paulo, Unidos da Vila Maria.

During this afternoon, participants will have the unique opportunity to learn how Competition skills are related to different samba school infrastructure during preparation for Carnival parades.

To end this experience in great style, WorldSkills São Paulo 2015 and Unidos da Vila Maria will invite the excursion participants for a fun and relaxing Brazilian churrasco (barbecue) as the official Welcome Reception.

Location: *Unidos da Vila Maria - Samba School 11 km from Anhembi Park, about 20 minutes by bus*

Departure and return: *Transportation for the combined Excursion and Welcome Reception will depart from Anhembi Park (bus station at the Samsung Pavilion) at 14:00, and will return at 20:00 from the event location back to the hotels. Be sure to board the bus that goes to your hotel in front of the main entrance of Unidos da Vila Maria.*



SIEMENS



Simplify your education in automation

Unique support for educators and students in educational institutions

Siemens Automation Cooperates with Education

Siemens Automation Cooperates with Education (SCE) focuses on the needs of students by providing educators with the tools and training to simplify their education in automation. The SCE program delivers value by offering specific courses, training curriculums and exceptional Hardware and Software Trainer Packages.

We are committed to sharing knowledge, resources and tools for teaching automation and drive system technologies through partnerships with educational institutions.



SIEMENS

Global Industry
Partner of
WorldSkills
International



siemens.com/sce



Altium

ENGINEERING INNOVATION FOR PCB DESIGN



Altium
Designer

Enterprise
altiumdesigner.com



CIRCUITSTUDIO

Professionals
circuitstudio.com



CIRCUITMAKER

Makers
circuitmaker.com



3M Science.
Applied to Life.™



We're working on the science of safe and sound

At 3M, we bring together science and imagination to create products that change the way we live and work. From personal protective equipment to health care, office products to industrial adhesives, we're leading the way forward.

www.3M.com



@3MEurope
#LifeWith3M



youtube.com/3M

2.2 Excursion and Welcome Reception for Competitors:

Sunday, 9 August 2015 (C-3)

Who will participate?

Competitors, Team Leaders, Official Delegates, and Official Observers

Excursion description: Traditional Brazilian party – “Festas Juninas”. Participants on this excursion will have an amazing day to relax and meet the other Delegations by participating in a traditional Brazilian party called Festa Junina*. The party will include Brazilian music and dances, as well as typical food, games, and many other attractions.

Participants will be greeted with a welcoming breakfast and invited to participate in activities and games throughout the day. Lunch, beverages, and snacks are included.

Location: Atibainha Countryside Hotel 80km from São Paulo

Departure: All participants will leave their hotel at 08:30 using the designated transport service to get to the Atibainha Countryside Hotel.

Return: The participants may leave the Atibainha Countryside Hotel and return to their respective hotels at 15:30.

*Festas Juninas are folk celebrations which were brought to Brazil by Portuguese colonizers. Over the years, this party has become a unique celebration with a wealth of regional expressions, particularly associated with the Northeast region in Brazil.

MILHARES DE JOVENS TALENTOS,
DEZENAS DE PAÍSES
E UMA MARCA DE TINTAS.

Suvinil. Patrocinadora da WorldSkills São Paulo 2015 e apoiadora do Ensino Técnico no Brasil.



SAC: 0800-011-7558
SUVINIL.COM.BR



Sua casa, seu orgulho.

11 August 2015 (C-1)

Teams visit One School One Country schools:

From 9:00 to 12:00

Who will participate?

Competitors, Team Leaders, and Official Delegates.

Description: One School One Country is an important part of the Competition, as it helps promote vocational skills education among young students. This initiative represents a unique opportunity to integrate students and educators in Brazil with visiting Competitors.

Fifty-five public (state and municipal) and private schools in São Paulo will participate in the programme. On 11 August, over 10,000 Brazilian primary school students (6th to 9th school years), 12-15 year olds, will be able to learn more about vocational education and labour market opportunities, as well as participate in fun activities and cultural presentations, encouraging information and experience exchanges between Competitors and young students.

Location: Each Delegation will visit one of the 55 schools selected in the city of São Paulo.

Departure: Each Delegation must check the shuttle departure schedule at their hotel.

Return: All participants will leave the schools at 11:30.

12 August 2015 (C1)

One School One Country schools visit the Competition

Over three days, 10,000+ students from the host schools will visit the Competition at Anhembi Park.

Wednesday: 10:00-17:00

Thursday and Friday: 09:00-17:00

Saturday: 09:00-16:00

2.4 Opening and Closing Ceremonies

Participants and Delegations that purchased a package or have a ticket to attend the Opening Ceremony and Closing Ceremony will find their tickets in their Welcome Kit. For more information and for questions please visit the Customer Service Team, they are available each day from 08:00 to 20:00 which is located in the Front Hall of the Convention Palace.

OPENING CEREMONY

Tuesday, 11 August 2015 (C -1)

Venue: Ibirapuera Gymnasium

Time:

16:00 – Doors Open

17:00 – Competitors and Team Leaders arrive

19:00 – **Ceremony begins**

21:30 – Ceremony ends

Inside the Ibirapuera Gymnasium

The Gym “Geraldo José de Almeida,” known as the Ibirapuera Gymnasium, is a landmark of the city of São Paulo. This is where the largest cultural events, sports, and leisure activities of our state take place. The venue will welcome approximately 7,220 spectators for the Opening Ceremony.

About the Opening Ceremony

The Competition Organizer WorldSkills São Paulo 2015 has prepared a great show to transform the Competition Opening Ceremony into an unforgettable celebration. The show will demonstrate the influence that five continents have had upon language, arts, music, dances, cuisine, and industry in Brazil, through a performance with over 400 dancers combined with special image, sound, and light effects. We hope you enjoy the celebration which we call “The World Chose Brazil!”

As a part of the Ceremony, all of the Brazilian regions - North, Northeast, Midwest, South and Southeast - will be represented with their landscapes, abundant natural resources, and regional culture. Everyone will have the opportunity to get to know how the efforts of immigrants from around the world have contributed to Brazil’s history and future as a successful country.

The overall theme for the Competition is “Choose”. We invite you tonight, to choose to honour and respect the WorldSkills movement and skills excellence worldwide by celebrating the Competitors and all that have worked so hard to be here. They chose their skill and to go beyond, you chose to train, support, mentor, educate, and believe in them.

Let’s make this the best Competition in history!

O MELHOR CAMINHO
SE FAZ COM EDUCAÇÃO.
A PSA PEUGEOT CITROËN
APOIA A WORLDSKILLS
SÃO PAULO 2015.



Professional Education.
There is NEWTON also here.



Font: Worldskills International



The Number One in Spray Equipment



Whether it be superb cars, exclusive musical instruments or designer furniture:
Whenever high gloss surfaces are desired,
SATA is the first choice.

For more information: www.sata.com

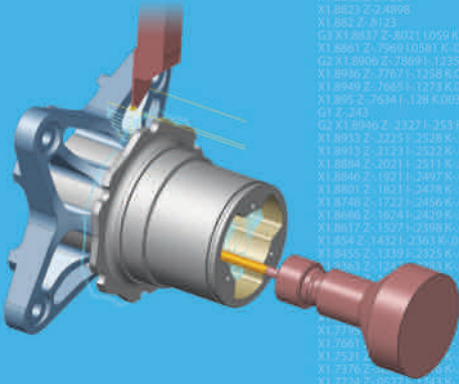

Mastercam®

BE DYNAMIC!

The future of speed and efficiency is here:
Mastercam's Dynamic Motion Technology

Official WorldSkills
Sponsor Since 2001



More information:
www.Mastercam.com
or contact your local reseller

X1 8832 Z-2-8998
X1 8832 Z-3123
G3 X1 8837 Z-3021 1059 K0
X1 8861 Z-7969 10581 K-0102
G2 X1 8906 Z-7868 1-1235 K-0333
X1 8936 Z-7762 1-1235 K-0225
X1 8949 Z-7665 1-1273 K-0134
X1 8952 Z-7634 1-128 K-0031
G F Z-343
G2 X1 8946 Z-3327 1-353 K0
X1 8933 Z-3233 1-3208 K-0102
X1 8913 Z-3123 1-2822 K-0205
X1 8894 Z-3021 1-2311 K-0307
X1 8846 Z-1921 1-3497 K-0409
X1 8801 Z-1821 1-3476 K-0509
X1 8748 Z-1722 1-3156 K-0609
X1 8686 Z-1626 K-2828 K-0708
X1 8617 Z-1527 1-2388 K-0808
X1 854 Z-1432 1-2363 K-0903
X1 8455 Z-1330 1-2325 K-0998
X1 8312 Z-1230 1-2313 K-1001
X1 8212 Z-1130 1-2313 K-1101
X1 7795 Z-1030 1-1529
X1 7681 Z-930 1-1609
X1 7521 Z-830 1-1687
X1 7376 Z-730 1-1762
X1 7234 Z-627 1-1743 K-1834

How to access the venue

Competitors, Team Leaders, and all other Delegates can take the shuttle bus from their hotels.

Please check the shuttle departure schedule from your hotel.

Arrival Process – Competitors and Team Leaders

All Competitors and Team Leaders must arrive at the Ibirapuera Gymnasium by 17:00 to prepare for the Parade of Nations. Again, please check the schedule for shuttle departure from your hotel in order to arrive by 17:00.

Competitors will not enter the Ibirapuera Gymnasium directly upon arrival. They will meet at an assembly point at the venue to prepare for the Parade of Nations.

There will be venue staff and WorldSkills São Paulo 2015 volunteers at the assembly point to direct Competitors and Team Leaders to the stage for the Parade of Nations inside the Ibirapuera Gymnasium.

Arrival Process – All Other Guests

All other guests should plan to arrive at the Ibirapuera Gymnasium by 18:00, to have enough time to find their seats to enjoy the Opening Ceremony.

Food and Drink

Water will be available inside the venue for free.

There will be concession stands selling soft drinks and simple snacks.

The Competitors and Team Leaders who take the official shuttle bus will receive a lunch box during the drive between the hotel and Ibirapuera Gymnasium.

Please note that all food options available at the food courts require cash or credit card payments.

Supporting the next generation.

Sumitomo Electric has supported a safe and comfortable living and practiced eco-friendly manufacturing.

We will continue to respond to the new needs of society with our far-sighted technology and products.



What to Bring?

You must bring your accreditation badge to access the venue. Access to Ibirapuera Gymnasium will not be possible without the accreditation badge.

The person responsible for each Delegation must ensure that all participants have their accreditation badge before leaving for the Ceremony. There will not be an accreditation centre at the Ibirapuera Gymnasium, so issuing a second copy will not be possible.

Departure

The Ceremony is scheduled to finish at 21:30. Shuttle buses will return to the hotels beginning at 21:45.

After the Ceremony, participants must board their busses to return to their hotels at the same location they were dropped off at. There will be a support team and appropriate signage to help.

Competitor Dress Code

Competitors should consult their Team Leaders regarding the dress code for the Ceremony to ensure suitable attire for the Parade of Nations.

Flags

WorldSkills São Paulo 2015 will provide the official flags for the Parade. Any small flags brought to the Ceremony must match the WorldSkills approved flags.

Any national or regional flags that do not match will be removed by security. Please check with your Official Delegate if you are unsure of what flag you should be using.



Studica

**WorldSkills Mobile Robotics
Competition Collection**

Available exclusively at
www.studica.com/worldskills



CLOSING CEREMONY

Sunday, 16 August 2015 (C+1)

Venue: Ibirapuera Gymnasium

Time:

15:30 – Doors Open

16:00 – Competitors and Team Leaders arrive

17:00 – Ceremony begins

20:00 – Ceremony ends

Inside the Ibirapuera Gymnasium

The "Geraldo José de Almeida," Gym, known as the Ibirapuera Gymnasium, is a landmark in the city of São Paulo. This is where the largest cultural events, sports, and leisure activities in the State take place. The venue will welcome approximately 8,500 spectators for the WorldSkills Closing Ceremony.

About the Closing Ceremony

The Closing Ceremony will create an extraordinary atmosphere for the most important and memorable moment in the entire event: the medals awarded to Competitors for their effort and dedication. The celebration will be magical - filled with interactive and entertaining illusions and performances, live interviews, and lots of music.

We will enjoy the retrospective video, looking back at the entire Competition and reliving its highlights. Looking ahead, we will get to learn a bit about Abu Dhabi, host of 44th WorldSkills Competition in 2017.

The final performance also promises to involve the audience with very traditional Brazilian music. The evening will be filled with surprises, laughter, and excitement! But most importantly it is the night that we find out who are the recipients of the medals in all fifty skills.



O MOVIMENTO MAIS BONITO DE 2015
UMA HOMENAGEM DE L'ORÉAL PROFESSIONNEL A TODOS
OS COLORISTAS E A TODOS OS APAIXONADOS POR COR.

MARQUE A HASHTAG #corquetransforma
NAS SUAS FOTOS E DECLARE O SEU AMOR PELA COR.

CONHEÇA MAIS EM:

lorealprofessionnel.com.br | segredosdesalao.com.br



[/lorealprofessionnel.br](https://www.facebook.com/lorealprofessionnel.br)



[@lorealprofbr](https://www.instagram.com/@lorealprofbr)

COLOR LOVER
L'ORÉAL PROFESSIONNEL

L'ORÉAL
PROFESSIONNEL
PARIS

How to access the venue

Competitors, Team Leaders, and all other accredited guests can take the shuttle bus from their hotels. Check the shuttle bus schedule in your hotel.

Arrival process – Competitors and Team Leaders

WorldSkills São Paulo 2015 will provide a separate access for the Competitors and Team Leaders. Please make sure that all Competitors and Team Leaders arrive at Ibirapuera Gymnasium by 16:00. Competitors and Team Leaders will be seated at the center of Ibirapuera Gymnasium.

Arrival process – All other guests

All other guests must arrive at Ibirapuera Gymnasium by 16:30, so they can have enough time to find their seat to enjoy the Closing Ceremony.

Food and Drink

Water will be available inside the venue for free.

There will be concession stands selling soft drinks and simple snacks.

Competitors and Team Leaders who take the official shuttle bus will receive a lunch box during the drive between the hotel and the Ibirapuera Gymnasium.

*Please note that all food options available at the food courts require cash or credit card payments.

What to bring?

You must bring your accreditation badge to access the venue. Access to Ibirapuera Gymnasium will not be possible without the accreditation badge. The person responsible for each Delegation must ensure that all participants have their accreditation badge before leaving to the Ceremony.

There will not be an accreditation centre at the Ibirapuera Gymnasium, so issuing a second badge will not be possible.

Departure

The Ceremony is scheduled to finish at 20:00. Shuttle buses for participants not attending the Farewell Party will return to the hotels beginning at 20:15.

A VIDA É FEITA DE ESCOLHAS E TODAS
ELAS TROUXERAM VOCÊ ATÉ AQUI.



COROLLA 2016
Cada vez mais irresistível.



RESPEITE A SINALIZAÇÃO DE TRÂNSITO. **FAÇA UM TEST DRIVE** Acesse: www.toyota.com.br

Programa Brasileiro de Etiquetagem Veicular (PBEV) 2015: Na categoria de veículos grandes, o veículo Toyota Corolla 2.0 16V nas versões Altis e XEi com transmissão Multidrive-S (CVT) de sete velocidades possui nota A no PBEV entre os veículos com menor consumo de combustível da categoria em 2015. O veículo Toyota Corolla 2.0 16V apresentou o seguinte consumo – etanol/ciclo urbano: 7,2 km/l; gasolina/ciclo urbano: 10,6 km/l; etanol/ciclo rodoviário: 8,8 km/l; gasolina/ciclo rodoviário: 12,6 km/l; CO₂ (fóssil não renovável) (g/km): 118 (gasolina). Valores de referência medidos em condições-padrão de laboratório, conforme NBR 7024, e ajustados para simular condições mais comuns de utilização, podendo não corresponder ao consumo verificado pelo motorista com o uso do veículo, que depende das condições do trânsito, do combustível, do veículo e dos hábitos do motorista. Para saber mais, consulte www.inmetro.gov.br e www.conpet.gov.br. A Toyota oferece três anos de garantia de fábrica para toda a linha sem limite de quilometragem para uso particular, e três anos ou 100.000 km (prevalecendo o que ocorrer primeiro) para uso comercial. Consulte o livrete de garantia, o manual do proprietário ou o site www.toyota.com.br para mais informações. A Toyota reserva-se o direito de alterar as especificações e características de seus produtos sem aviso prévio. Todas as versões do Corolla vêm com tapetes genuínos Toyota de série. Imagens da versão Altis ilustrativas.



TOYOTA
Pensando mais longe

Competitor Dress Code

Competitors should consult their Team Leaders regarding the dress code for the Closing Ceremony.

Flags

Any small flags brought to the Ceremony must match the WorldSkills approved flags. Any national or regional flag that does not match will be removed by security. Please check with your Official Delegate if you are unsure of what flag you should be using.

Seating

The Delegation will have allocated seating areas printed on their accreditation badge and they can choose which seat to take within this allocated area.

Competitors and Team Leaders also have allocated seating in the centre of the Ibirapuera Gymnasium arena according to their countries and the Parade of Nations.

Entry will not be permitted without an accreditation badge.

2.5 Farewell Party

The Farewell Party will be at Ibirapuera Gymnasium Complex.

2.6 WorldSkills São Paulo 2015 Conference Programme

The WorldSkills São Paulo 2015 Conference Programme is designed to provide an opportunity to exchange best practices, learn from world-class experts in skills development, and enable networking among industry, government, and education leaders - all of whom are informing and inspiring adults and youth about vocational skills education.

THE NEW
FIAT 500
CABRIO



Power-retractable soft top with three preset positions



Dual Drive Electric Power Steering



Leo Burnett/Tator Media



Pedestre, use sua faixa.

Imagens meramente ilustrativas, com alguns itens opcionais.
fiat.com.br/500 - SAC 0800 707 1000 / 0800 282 1001

DRIVEN BY PASSION.



CONFERENCE PROGRAMME SCHEDULE

	TUE. 11 AUG. (C-1)	WED. 12 AUG. (C1)	THUR. 13 AUG. (C2)	FRI. 14 AUG. (C3)	SAT. 15 AUG. (C4)	SUN. 16 AUG. (C+1)
Competition events	Opening Ceremony	Day 1 of Competition	Day 2 of Competition	Day 3 of Competition	Day 4 of Competition	Closing Ceremony
Daily theme	SENAI and Industry excellence	Future trends	Exploring skills excellence	Global policies and innovation	Skills development initiatives	Explore São Paulo
Morning programme		Skills for sustainable development post-2015	WorldSkills Leaders Forum: the future of skills development and excellence	International Ministers Conference – 21st century initiatives to foster technical and vocational education	Seminars on countries approaches to skills excellence and development	
Afternoon programme (pick one of the options)	Industry and SENAI schools technical visits	Prospective methodologies for skills development – hosted by ILO	Guided VIP tour of the Competition Skills development for Africa – hosted by World Bank	A glimpse at industries future skills and technologies – hosted by Global Partners Creating a joint vision for skills development – hosted by BRICS		Guided tour in São Paulo City
Alternative options for afternoon		Guided tour of Competition Restaurant Service guest Additional Industry or education study visit (based on demand)		Guided tour of Competition Restaurant Service guest Additional Industry or education study visit (based on demand)	Guided tour of Competition Restaurant Service guest	
Evening programme		An evening with UNEVOC – network and reception				
Cost per day*	USD 70	USD 180	USD 150	USD 100	USD 100	USD 120
Additional items Included in cost per day	Industry and education visit transfers Lunch	Coffee Break Lunch at Holiday Inn Networking Lounge Access	Coffee Break WSLF Lunch Networking Lounge Access	Coffee Break Lunch at Holiday Inn Networking Lounge Access	Coffee Break Lunch at Holiday Inn Networking Lounge Access	Lunch
	There will be an additional general registration fee of USD 130 that is a one-time payment for the Conference Days on C1-C4. *These prices are for the Conference programme components only. They do not include accommodations and transfers.					

WorldSkills Connect

www.worldskillsconnect.com

WorldSkills Connect is an online tool for people at WorldSkills São Paulo 2015 to find other people with similar interests and arrange to meet.

It is an essential tool to enhance your networking opportunities.

Partnership Hall

Partnership Hall will be a unique spot for networking and business meetings, where leaders can meet one another informally as well as through scheduled meetings.

The intention behind this exclusive environment is that it will be a place in which representatives of WorldSkills Member countries and regions, and leaders can connect, network, and explore partnership possibilities both nationally and internationally.

2.7 WorldSkills Village

The WorldSkills Village is an international exhibition held during the Competition. It includes areas for WorldSkills Member countries and regions, and SENAI partners, as well as host countries for upcoming Competitions.

In addition, the Village includes exhibition stands for educational institutions, public entities, and partners and sponsors.



A brand of MAN Latin America.
www.man-la.com

Constellation 24.280.
The sales leader*
now in version 8x2.

• Up to 5 tons more
of liquid cargo

Caminhões sob medida.



*Fonte: BIVWAVE 2014 (dados referentes ao ano 2014)
All together make a better transit.



Na Amada Technical Center você encontra a solução perfeita!

AT AMADA TECHNICAL CENTER YOU FIND THE PERFECT SOLUTION!

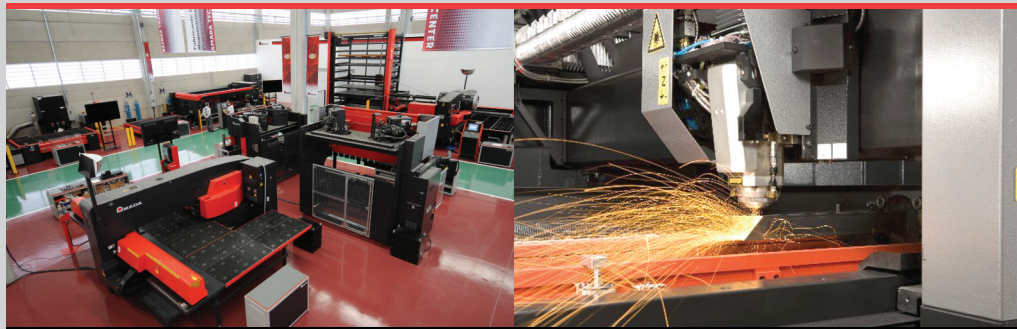

CORTE A LASER

LASER CUTTING TECHNOLOGY

PUNCIÓNADEIRA

TURRET PUNCH PRESSES

DOBRADEIRA

PRESS BRAKE

www.amada.com.br

Av. Tamboré, 965/973 . Tamboré . CEP 06460-000 . Barueri . SP
Tel.: (11) 4134-2324 . Fax: (11) 4134-2329

 Corporate Social Responsibility
csr.cisco.com

DEVELOPING THE FUTURE TALENT AND EXPANDING OPPORTUNITIES IN YOUR COMMUNITY

The Cisco Networking Academy® program prepares students for careers in Information and Communications Technology (ICT) by fostering public-private partnerships with national, regional, and local organizations.

As the Internet of Everything becomes the driving force for jobs and innovation, Cisco and the Networking Academy are helping train and create opportunities for the future workforce.

Learn more:
www.NetAcad.com

impact^x

EXHIBITORS:

<p>WorldSkills Members and Competition hosts</p>	<p>Austria Belarus Canada Finland France Germany India Japan Netherlands Russia Saudi Arabia South Korea Sweden Chinese-Taipei United Kingdom WorldSkills of America WorldSkills Abu Dhabi 2017</p>
<p>WorldSkills Foundation</p>	<p>3M-Listen Up WorldSkills Digital Challenge</p>
<p>Institutional Partners</p>	<p>FIEMG</p>
<p>Exhibitor/Company</p>	<p>Electude</p>
<p>WorldSkills Global Partners</p>	<p>American Welding Society</p>
<p>Sponsors</p>	<p>Nestlé</p>



3. SERVICES AND FACILITIES

3.1 Customer Service

The Competition Organizer WorldSkills São Paulo 2015 endeavours to provide a great support and Customer Service throughout your stay in São Paulo.

To ensure that our Members and Delegates will have a great experience, all assistance will be provided by our Customer Service Team during the whole period of the event, from 08:00 to 20:00. You are more than welcome to visit our Customer Service Area, located at the Front Hall of the Convention Palace, for any enquiries regarding hospitality services.

Hotline:

The visitor hotline will be operational as per the following schedule:

05 - 17 August: 06:00 to 22:00

The WorldSkills São Paulo 2015 Hotline is: 0800 580 0834

If you cannot reach us via the hotline or, please send your enquiries to customerservice@wssp2015.com or call us back during the operating hours.



Considered one of the most desired companies by Brazilian youngsters, Nestlé invests in several programs to contribute with youth professional development, such as: Apprentices, Interns and Trainees.

Nestlé supports WorldSkills 2015 and believes that professional and technical education are critical to transform society and change lives.

3.2 Hotels

Below is the list of official WorldSkills São Paulo 2015 hotels.

HOTELS	ADDRESS	TELEPHONE	WEBSITE
Blue Tree Paulista	Rua Peixoto Gomide, 707 - Cerqueira César	+55 0 11 3147-7000	www.bluetree.com.br/hotel/blue-tree-premium-paulista
Bourbon Business	Avenida Doutor Vieira de Carvalho, 99 - República	+55 0 11 3337-2000	www.bourbon.com.br/hotel/midscale-pt/business-hotel-pt/bourbon-sao-paulo-business-hotel/
Braston Hotel São Paulo	Rua Martins Fontes, 330 - Consolação	+55 0 11 3156-2400	www.braston.com
Comfort Downtown	Rua Araújo, 141 - República	+55 0 11 2137-4600	www.atlanticahotels.com.br/hotel/sao-paulo/comfort-hotel-downtown
Dan Inn Planalto	Avenida Cásper Líbero, 115 - Centro	+55 0 11 3227-7916	www.daninnhotel.com.br
Estanplaza Paulista	Alameda Jaú, 497 - Cerqueira César	+55 0 11 3016-0000	www.estanplaza.com.br/hoteis/pt-br/estanplaza-paulista/#12
Feller Avenida Paulista	Rua São Carlos do Pinhal, 200 - Bela Vista	+55 0 11 3016-7500	www.fellerhoteis.com
Golden Tulip Belas Artes	Rua Frei Caneca, 1199 - Consolação	+55 0 11 2627-6300	www.goldentulipbelasartes.com/pt-pt/contatos
Hampton Park	Alameda Campinas, 1213 - região da Av.Paulista	+55 0 11 2627-1800	www.bhghoteis.com.br/hampton-park/

HOTELS	ADDRESS	TELEPHONE	WEBSITE
HB Hotels Ninety Jardins	Alameda Lorena, 521 - Jardim Paulista	+55 0 11 3055-6800	www.hbhotels.com.br
Holiday Inn Parque Anhembi	Rua Professor Milton Rodriguez, 100 - Santana	+55 0 11 2107-8844	www.holidayanhembi.com.br/
L'Hotel Porto Bay Sp	Alameda Campinas, 266 - Jardim Paulista	+55 0 11 2183-0500	www.portobay.com/pt/hoteis/ brasil/sao-paulo-brasil/hotel- porto-bay-sao-paulo/
Maksoud Plaza	Alameda Campinas, 156 - Jardim Paulista	+55 0 11 3145-8000	www.maksoud.com.br
Hotel Marabá	Avenida Ipiranga, 757 - Centro	+55 0 11 2137-9500	www.hotelmaraba.com.br
Matsubara Hotel São Paulo	Rua Coronel Oscar Porto, 836 - Paraíso	+55 0 11 3561-5000	www.matsubarasaopaulo. com.br
Meliá Paulista	Avenida Paulista, 2181 - Consolação	+55 0 11 2184-1600	www.melia.com/pt/hoteis/ brasil/sao-paulo/melia-paulista/ index.html

HOTELS	ADDRESS	TELEPHONE	WEBSITE
Panamby São Paulo	Avenida Ordem e Progresso, 115 - Barra Funda	+55 0 11 3103-0500	www.hotelpanambysaopaulo.com.br
Paulista Wall Street Suites	Rua Itapeva, 636 - Bela Vista	+55 0 11 3141-3000	www.wallstreet.com.br
Pergamon Hotel	Rua Frei Caneca, 80 - Consolação	+55 0 11 3123-2033	www.bhghoteis.com.br/pergamon/
Pestana Hotels & Resorts	Rua Tutóia, 77 - Jardim Paulista	+55 0 11 3059-5000	www.pestana.com/br/hotel/pestana-sao-paulo
Quality Jardins	Alameda Campinas, 540 - Jardim Paulista	+55 0 11 2182-0400	www.atlanticahotels.com.br/hotel/sao-paulo/quality-jardins
Quality Suites Bela Cintra	Rua Bela Cintra, 521 - Consolação	+55 0 11 3728-0800	www.atlanticahotels.com.br/hotel/sao-paulo/quality-suites-long-stay-bela-cintra
San Raphael	Largo do Arouche, 150 - Centro	+55 0 11 3334-6000	www.sanraphaelhotel.com.br
Slaviero Executive São Paulo	Alameda Campinas, 1435 - Jardim Paulista	+55 0 11 3886-8500	www.slavierohoteis.com.br/hotel-em-sao-paulo/slaviero-executive-sao-paulo-jardins/hotel/
Tivoli Hotels & Resorts	Alameda Santos, 1437 - Cerqueira César	+55 0 11 3146-5900	www.tivolihotels.com/br/hoteis/sao-paulo/tivoli-sao-paulo-mofarrej/o-hotel.aspx

Packages include breakfast and Wifi. However, all other incidentals and expenses must be paid directly at hotel check-out because they are not included in the purchased package.*

**Incidentals and expenses examples: laundry, telephone calls, spa, mini bar, meals in restaurants, bar items, or room service. According to the international hospitality policy, hotels will request a credit card at check-in as a guarantee for any expenses. Check-in starts at 15:00 and checkout is before 12:00.*

HOTELS	ADDRESS	TELEPHONE	WEBSITE
Transamérica International Plaza	Alameda Santos, 981 - Jardim Paulista	+55 0 11 3146-5966	www.transamericagroup.com.br/nossos-hoteis/prime-international/
Trianon Paulista	Alameda Casa Branca, 355 - Cerqueira César	+55 0 11 2117-4450	www.hoteltrianon.com.br/
Tryp Higienópolis	Rua Maranhão, 371 - Higienópolis	+55 0 11 3665-8200	www.melia.com/pt/hoteis/brasil/sao-paulo/tryp-sao-paulo-higienopolis-hotel/index.html
Tryp Paulista	Rua Haddock Lobo, 294 - Cerqueira César	+55 0 11 3123-6200	www.melia.com/pt/hoteis/brasil/sao-paulo/tryp-sao-paulo-paulista-hotel/index.html
Unique Hotel	Avenida Brigadeiro Luís Antonio, 4700 - Jardim Paulista	+55 0 11 3055-4700	www.hotelunique.com.br
WZ Century Paulista	Rua Teixeira da Silva, 647 - Paraíso	+55 0 11 3882-9977	www.centuryflat.com.br/site/contato.php
WZ Jardins	Avenida Rebouças, 955 - Pinheiros	+55 0 11 3069-0000	www.wzjardins.com.br

Ford Motor Company stimulates education and supports the **Worldskills Competition São Paulo 2015**, and also reiterates its commitment with qualification and professional development of future generations.

Participants who need additional days in the hotel, either before or after the pre-established period for the package, will be responsible for the request and payment directly to Terramar, the official event travel agency.

Delegate hotels will have a Help Desk service where there will be professionals (Guardian Angels) available to provide general information and support.

This service will be provided at the hotel front desk with official Competition signage.

3.3 Transportation

Three types of services provide:

1. Transfers from airports to hotels

A bilingual team (Portuguese and English) with standard uniforms will be at the airports to welcome Delegations and guide them to the specific transfer going to their hotel.

A transfer service going back to the airports will also be provided, according to the information registered in the package reservation system.

The transportation service will only be provided for official participants that purchased packages.

2. Daily transfers to Anhembi Park

During the Competition days, daily transportation services from the hotels to Anhembi Park will be provided according to the schedule below:

12-15 August (C1-C4)

Departure from hotels: 06:00-08:00

Returning to the hotels: starting at 17:00

This service will be available in the bus parking area, near the Samsung Pavilion, according to the schedule below:

Sinapse

Print Simulators



Train



**Better
Faster,
Cheaper.**

Visit www.sinapseprint.com for the latest news!

<i>Line</i>	<i>Hotels</i>
A	Anhembi Hostel Panamby São Paulo Holliday Inn Express Tryp Higienópolis Dan Inn Planalto Excelsior Hotel Marabá Comfort Downtown San Raphael Bourbon Business
B	Braston Hotel São Paulo Pergamon Hotel Tryp Paulista Meliá Paulista Quality Suites Bela Cintra Paulista Wall Street Suites Blue Tree Paulista Golden Tulip Belas Artes Feller Av. Paulista WZ Jardins
C	Estanplaza Paulista Renaissance Tivoli Hotels & Resorts Intercontinental São Paulo Transamérica International Plaza Trianon Paulista Quality Jardins L'Hotel Porto Bay SP Maksoud Plaza Slaviero Executive São Paulo
D	Hampton Park HB Hotels Ninety Jardins Unique Hotel Matsubara Hotel São Paulo Pestana Hotels & Resorts WZ Century Paulista Grand Plaza Golden Tulip Paulista Plaza Grand Hyatt São Paulo Sheraton São Paulo WTC Hotel
E	Holiday Inn Parque Anhembi

3. All-day transportation service to Anhembi Park

An all-day transportation service from Anhembi Park to the official hotels will be available from 08:00-16:00, 12-15 August (C1-C4), running on a 2-hour interval.

These are bus lines departing from Anhembi Park and going to specific hotels on pre-established schedules, according to the chart below. Information about schedules and itineraries should be confirmed at the transportation office in the Samsung Pavilion or at the official hotel lobby. If you have any questions, please ask your Guardian Angel, who will be your main contact with the transport coordination team.

Line	Hotels
1	Bourbon Business San Raphael Hotel Marabá Excelsior
2	Trianon Paulista Tivoli Hotels & Resorts Maksoud Plaza Feller Paulista Matsubara Hotel São Paulo
3	L'Hotel Porto Bay SP Quality Jardins HB Hotels Ninety Jardins Estanzola Paulista Slaviero Executive São Paulo
4	Meliá Paulista Unique Hotel Pestana Hotels & Resorts WZ Century Paulista
5	Tryp São Paulo Paulista Confort Downtown Pergamon Hotel Dan Inn Planalto Braston Hotel São Paulo
6	WZ Jardins Quality Suites Bela Cintra Golden Tulip Belas Artes Blue Tree Paulista Paulista Wall Street Suites
7	Panamby São Paulo Tryp Higienópolis São Paulo Transamérica International Plaza
8	Golden Tulip Paulista Plaza Grand Plaza Hampton Park
9	Renaissance and Intercontinental
10	Grand Hyatt São Paulo

3.4 Accreditation

Participants will receive their accreditation badges and their Welcome Kits at their package hotels.

Wearing the accreditation badge is mandatory within Anhembi Park, as well as in all external WorldSkills São Paulo 2015 events for personal identification and access purposes to ensure access privileges, such as the types of access and days allowed, transportation, meals, etc. The legend for the symbols and information about specific areas will be detailed on the back of the accreditation badge.

Wearing the accreditation badge is also mandatory during the Opening and Closing Ceremonies, Farewell Party, and excursions.

For those participants under 18 years of age, the accreditation badge will show a symbol indicating that they are not be allowed to consume alcohol during the Farewell Party.

For Competitors and Team Leaders, the badge itself will not allow access to external events except for Opening Ceremony, Closing Ceremony, and Farewell party. For all the others external events a ticket or invitation must be presented at the entrance.

WHERE QUALITY
COMES TOGETHER



HEXAGON
METROLOGY

Soluções em metrologia industrial que aumentam a qualidade e a performance em todos os processos fabris.

www.hexagonmetrology.com.br

f.: + 55 (11) 5525.6000

WorldSkills São Paulo 2015 will have four Accreditation Centres at Anhembi Park: one in the Sambadrome, two in the Convention Palace, and one in the Samsung Pavilion. The Accreditation Centre located in the Samsung Pavilion will provide priority assistance for delegations.

Normal operating hours for all Accreditation Centres will be 07:00-20:00 from C-6 on. If necessary, the operating schedules and period may be changed to better meet participant needs.

The accreditation badges and access permission wristbands for Competitors' families and supporters will be distributed at the Accreditation Centre located in the Samsung Pavilion. To pick up the Competitor Supporter (family and friends), Technical Delegates must go to the Accreditation Centre in the Samsung Pavilion and present a list with the names for those who should receive the wristband.

This access wristband will allow entrance to Anhembi Park after the regular public visiting times to support those Competitors finishing competition after regular public visiting times.

For any questions or to receive more information, please contact us by email: accreditation@wssp2015.com, or come and see us at the Accreditation Centres onsite.

**The worldwide STANDARD for
home and building control**



- 375 Manufacturers
- 7000 Certified Products
- One Standard: ISO/IEC 14543
- One Tool: ETS
- All Media: TP, PL, RF, IP

KNX projects

in 125 countries

Worldskills São Paulo 2015

Electrical Installations Supporter

www.knx.org

3.5 Catering

WorldSkills São Paulo 2015 has put a lot of effort into preparing high quality catering services to ensure that all participants have access to a variety of food options and that - as much as possible - their individual and cultural eating habits and needs are met. Participants should really enjoy their meals.

Important notice

For packages, all included meals and drinks begin the day after arrival and end at breakfast the last day of the package. The only exception is for Competitors and Team Leaders, who will receive a welcome snack together with their accreditation badge upon arrival at the hotels.

Breakfast

Breakfast is included in all participant packages and will be served at the hotels.

Drinks and snacks

Drinks and snacks will be served daily to Official Observers, Observers, Experts, Official Delegates, Team Leaders, Technical Delegates, and Technical Delegate Assistants at their work/meeting rooms.

Drinks and snacks will include: coffee, tea, water, various snacks, and fruits.

THIS IS NOT A BEDROOM
IT'S A FACTORY WHERE AWESOME
DREAMS ARE MANUFACTURED

SAINT-GOBAIN

STAND
47
CASE STUDY



Delegate restaurants

There are two Delegate restaurants at Anhembi Park - one in the Sambadrome (Samba Restaurant) and one next to the Holiday Inn (Brasil Restaurant).

A specific restaurant will be designated for each Competitor and Expert depending on the location of their skill competition.

The "Samba Restaurant" will be open from 8-15 August (C-4 to C4) from 11:00-14:00, and the "Brasil Restaurant" will be open from 6-15 August (C-6 to C+1) from 11:00-14:00.

Menu will change daily and be displayed on the menu boards inside the restaurant. Lunch and dinner menus will always include: beef, fish, and poultry.

Everyday there will be pasta and side dishes such as vegetables, rice and beans, which are recommended for vegetarians. Additionally, there will be packaged salad, yogurt, fruit, and desserts. Drinks will be offered such as water, soft drinks, and juices every meal. Pork will not be served.

Lunch

All participants with a package are entitled to have lunch. Lunch will be served 11:00-14:00 daily.

Competitors and Experts will have a specific lunch slot for 9 August (C-2) and the Competition days defined in their Skill Management Plan.

More than 3,500 meals a day will be served at WorldSkills Sao Paulo 2015; so, cooperation to ensure lunch proceeds as smoothly as possible will be appreciated.

A fast lane for Competitors will be available.

Danfoss Learning **Learning is Earning**

Danfoss Learning is your online access point to knowledge. Choose from an extensive catalogue of virtual and face-to-face courses and gain confidence and sales potential as your skills improve.

Learn

and improve your chance of success. Quick learning and easy understanding.

learn

ENGINEERING
TOMORROW

Danfoss

www.learning.danfoss.com

“Brasil Restaurant” – Lunch Time

	C-6	C-5	C-4	C-3	C-2	C-1
	06.08.15 thursday	07.08.15 friday	08.08.15 saturday	09.08.15 sunday	10.08.15 monday	11.08.15 tuesday
	11:00-14:00	11:00-14:00	11:00-14:00	11:00-14:00	11:00-14:00	11:00-14:00*
LUNCH	C1	C2	C3	C4	C+1	
	12.08.15 wednesday	13.08.15 thursday	14.08.15 friday	15.08.15 saturday	16.08.15 sunday	
	11:00-14:00	11:00-14:00	11:00-14:00	11:00-14:00	11:00-14:00**	

“Restaurant Samba”– Lunch Time

	C-4	C-3	C-2	C-1	C1	C2
	08.08.15 saturday	09.08.15 sunday	10.08.15 monday	11.08.15 tuesday	12.08.15 wednesday	13.08.15 thursday
	11:00-14:00	11:00-14:00	11:00-14:00	11:00-14:00*	11:00-14:00	11:00-14:00
LUNCH	C3	C4				
	14.08.15 friday	15.08.15 saturday				
	11:00-14:00	11:00-14:00				

Important Notice:

*C-1 (11.08.15) - for those who will attend the OSOC programme (C, TL, OD, TD), the lunch will be served at their hotels, except for participants who are at the Holiday Inn. They will have lunch at Anhembi Park in the Brasil Restaurant and Samba Restaurant.

** C+1 (16.08.15) - for those who will not be at Anhembi Park and are not staying at the Holiday Inn, lunch will be served at their hotels.

Dinner

Dinner is only included for Competitors and Team Leaders from 17:00-19:30 at the Brasil Restaurant during their stay, with the exceptions of 11 August (C-1) and 16 August (C+1) where they will receive a packaged meal.

For Experts, Interpreters, Technical Delegates, and Technical Delegate Assistants dinner is only served on 15 August (C4) at the Brasil Restaurant and the Samba Restaurant.

“Brasil Restaurant” – Dinner Time

	C-6	C-5	C-4	C-3	C-2	C-1
	06.08.15 thursday	07.08.15 friday	08.08.15 saturday	09.08.15 sunday	10.08.15 monday	11.08.15 tuesday
	17:00-19:30	17:00-19:30	17:00-19:30	17:00-19:30	17:00-19:30	Packaged Meal
DINNER	C1	C2	C3	C4	C+1	
	12.08.15 wednesday	13.08.15 thursday	14.08.15 friday	15.08.15 saturday	16.08.15 sunday	
	17:00-19:30	17:00-19:30	17:00-19:30	17:00-19:30	Packaged Meal	

Skill Out

Skill Out will take place at the Convention Palace terrace from 8-15 August (C-4 to C4), 17:00-20:00 (with the exception of C-1 as this is the Opening Ceremony) - for all participants who have this included in their packages.

Enjoy a snack and drinks in a relaxing atmosphere with your Skill Out vouchers, which can be found in your accreditation badge. The number of vouchers you receive depends on the number of Competition days that your package includes.

What measures
can you take to ensure
correct collision estimation?



Food Courts

During the Competition period, there will be two food courts: one at the Pavilion and another at the Sambadrome. They will offer several options of food, snacks, drinks, and sweets.

**Please note that all food options available at the food courts require cash or credit card payments.*

3.6 Information technology - support and services

Mobile phones

The Competition Organizer da WorldSkills São Paulo 2015 will provide mobile phones for Official Delegates, Technical Delegates, Chief Experts, Deputy Chief Experts, Workshop Managers, Team Leaders (maximum of 2 per Member), and WorldSkills International. You can pick up your mobile phone at the Radio and Telephone Centre in the Samsung Pavilion.

Please note

Mobile phones must be returned to the Radio and Telephone Centre before departure, or on 16 August, whichever comes first. If a mobile phone is not returned, the cost will be charged to the respective Member by the WorldSkills São Paulo 2015 Competition Organizer.

Your phone will initially receive 60 minutes for local, national, and international calls; free intragroup calls inside the city of São Paulo; unlimited national SMS service and 3G Internet (1 GB). You can recharge credit using your international credit card: BRL 65.00 for 60 more minutes; BRL 59.00 for a 3G Internet recharge, limited to 1 GB. There will be helpdesk services available in Portuguese and English 08:00-20:00 at the Radio and Telephone Centre 8-16 August (C-4 to C+1).

Internet access

There will be wireless Internet available at the venue, especially at Wi-Fi zones like Cyber, the Food Court at the Samsung Pavilion, and at the Food Court in the Sambadrome.

3.7 Volunteers

WorldSkills São Paulo 2015 volunteers will provide necessary support in areas where Competitors and visitors will be present. They will also be at the airport to receive all of the Competitors helping to answer any questions.

In addition, an Attaché will be assigned to each delegation to support the Team Leader and Competitors during their stay in São Paulo. You will meet your Attaché personally upon arrival at the airport. The Attaché will help you get your accreditation badges, and will assist you with your check-in at the hotel.

In addition, the Attaché will accompany your team during the excursions and help them at the Opening and Closing Ceremonies. The Attaché will have a cell phone, and will be available to answer your questions and requests.

This phone number will be provided to you by your Attaché when you arrive. All volunteers will do their best to contribute to the success of WorldSkills São Paulo 2015!

3.8 Press Centre

The Press Centre is located at the Convention Palace, on the access road to the Sambadrome. This is the work area designated for representatives of the press who are covering the event. Capacity: maximum of 200 people at any one time. Open 10-17 August according to the following schedule:

10 August 2015: 12:00-20:00

11 August 2015: 08:00-02:00 (12 August)

12 August 2015: 08:00-20:00

13 August 2015: 08:00-20:00

14 August 2015: 08:00-20:00

15 August 2015: 08:00-20:00

16 August 2015: 08:00-03:00 (17 August)

17 August 2015: 08:00-14:00

To keep press up-to-date about the Competition, we are planning on having a daily media briefing session every morning for 30 minutes at Press Briefing Room (check the schedule on the Official Media Website: <http://media.worldskills.org>) where press can get the latest Competition schedule information, and ask questions.

In addition, we will have screens in the Press Centre providing regular news and updates about WorldSkills São Paulo 2015. Access to the Press Centre requires press accreditation.

Test Tools for the
Next Generation
of Skilled
Professionals



Sponsored by

FLUKE

FLUKE
networks

3.9 Safety and emergency procedures

Purpose

The purpose of these procedures is to ensure, as much as possible, the safety, health, and well-being of the participants, workers, students, and visitors during WorldSkills São Paulo 2015.

In order to comply with the relevant Brazilian legislation, the WorldSkills Health, Safety, and Environmental policy and guidelines were prepared and distributed, and all of the spaces have emergency alert systems installed. An Emergency Control Team is organized and trained to help out with possible occurrences.

Emergency control team

The Emergency Control Team consists of Workshop Managers, Civil Fire Department, Emergency Brigade, Security, Security Guards Coordinator, Medical Coordinator of the Health Service, Occupational Safety Coordinator, as well as external agents, such as emergency and fire services.

The Emergency Control Team's role is to ensure the safety of all who attend WorldSkills São Paulo 2015, and quick services for any kinds of emergencies that may occur. During emergency situations, this team will provide the necessary instructions, with approval from the Health, Safety, and Environment teams.

We would like to also ask all participants to become familiar with the emergency alarms available, glass break alarms, evacuation plans, emergency exits, assembly points, as well as the Workshop Managers, Fire Department, and Emergency Brigade workers present in your area and space.

Security

Access and circulation areas in different event spaces will be monitored through internal circuit monitoring. The recorded images are confidential and will be stored for future procedures.

**MIRKA**

Dust-Free Sanding

Healthier Work Environment
Higher Performance and Productivity
Minimize Dust Contamination



Abranet Ace
Dustless sanding
Autonet
Dustless sanding
MIRKA



Phone: +55 11 3637 5492 (LIXA)

www.mirka.com.br

Medical service

In order to assist all of the WorldSkills São Paulo 2015 participants, we will have seven advanced medical assistance points in the venue, distributed in strategic positions as shown in the specific map in this handbook.

There will always be ambulances for quick assistance, with mobile intensive care units and four basic support units, during the Competition's official operating hours at the Competition venue, as well as in the hotels in which participants on packages are staying.

In addition to the ambulances, we will have a large team of civil firefighter-rescuers, trained to provide first aid and rescue services. These firefighters will be positioned in strategic locations, according to the event risk maps.

If a Competitor or Expert uses regular medication or requires regular medical supervision (e.g. self-applied injection with adrenaline, insulin, continuous use heart medication), the Chief Expert and Workshop Manager must be notified before preparation and familiarization begins.

Details about these medical conditions must be documented using the Anaphylaxis Action Plan form or Asthma Action Plan provided to the Technical Delegates. The Anaphylaxis Action Plan should be displayed on the wall of the Workshop Manager's office.

**Os melhores profissionais
exigem o melhor.
E escolhem Gedore.**

*The best professionals
require the **best** tools.
And they choose **Gedore**.*



www.gedore.com.br

GEDORE



Líder pela Qualidade · Werkzeuge fürs Leben

Emergency evacuation plan and escape routes

At all times during an emergency, please follow the instructions provided by the Workshop Managers.

- *At any times, an evacuation order may be communicated, through an alarm or verbally, "You must evacuate immediately!";*
- *Whether you hear an evacuation alarm or verbal instructions from a Workshop Manager, abandon the venue through the nearest and safest escape route, which will take you to a specific assembly point. All doors must be closed - but not locked - when leaving. Once outside the building, keep streets and access free for the Fire Department and health assistance services;*
- *Help anyone with special needs to leave the venue, or take them to either a place that is isolated from the risk or the closest safe assembly point;*
- *Keep calm! Walk, do not run, and go to the nearest emergency assembly point and follow the Safety and Environment Team instructions (Fire Department and Brigade);*
- *Stay in groups at the assembly point until you receive instructions from a Workshop Manager or emergency service personnel indicating it is alright to return to the venue or leave the venue. Do not enter an area when the emergency alarm is ringing.*

THE FUTURE IS BUILT THROUGH EDUCATION.

Starrett's support education in Brasil and at all Latin America tought the encourage some multidisciplinary projects. The **Starrett's + Universities** program has already supported more than **160 teams** and **pioneering ideas** that include high technology, focused in quality, performance and results.

Know this:
www.starrett.com.br/universidades

Starrett®



Fire and smoke

If you see or smell either fire or smoke, activate the alarm!

- 1. If it is safe to do so, ensure the immediate safety of anyone within the immediate fire area;*
- 2. Activate the fire alarm if it still hasn't been switched on by using the manual alarm activation or yell "FIRE! FIRE! FIRE!", if there isn't an alarm near;*
- 3. Evacuate the area immediately;*
- 4. Do not return to the venue before the Workshop Manager or Health, Safety and Environment team (Fire Department/Brigade and Doctor) say it is safe to do so.*

Emergency measures

The Competition Organizer guarantees that there are emergency plans and measures in place throughout the entire Competition venue. During the event, our emergency control team will take on the necessary safety precautions in the following situations:

- 1. Organize a rescue chain for cases where there are injuries or accidents;*
- 2. Chemical/spill/gas leak contamination;*
- 3. Alarm and Emergency Plan.*

Personal injury

- 1. Please contact the Workshop Manager or closest Emergency Control Team;*
- 2. Send the injured party to the Medical Centre, if necessary*
- 3. Become acquainted with the location of the first aid kit and Civil Fire Department/Brigade in your area;*
- 4. If you are robbed: notify the Workshop Manager or nearest Security Guard and provide details about the occurrence;*

Responsibilities for persons with special needs

- 1. Whether your disability is temporary or permanent, whenever possible it is important for you to know your own needs and follow the necessary instructions for emergency situations or evacuation plans.*
- 2. Please know that you can ask for help and should clearly communicate your needs.*
- 3. Become acquainted with the exit routes, and check to see if these are appropriate for your needs, even if they are not part of your circulation route;*

4. Remember, you are encouraged to specify what kind of assistance you may require from others during an emergency. Do not assume that people around you will know what to do.

Assistance for persons with physical disabilities

1. Do not provide physical guidance, hold, lift, or carry a conscious person without their permission. This includes refraining from pushing someone in a wheelchair, or “rushing” them forward without their permission.
2. Ask what kind of help the person needs. For example, see if you should clear the path ahead, or walk beside or behind them. Try to avoid providing advice or guessing what the person needs if you don’t know them.

3.10 Sustainability at WorldSkills São Paulo 2015

Our sustainability commitment with each WorldSkills Competition constantly grows. We have developed some actions for WorldSkills São Paulo 2015 that help promote an environmentally responsible, socially just, and economically feasible event.

Some of the main actions include: solid waste management, recyclable materials sent to cooperative trash collection centres and waste separated and processed on site.

We would also like to highlight the neutralization process for greenhouse gases through carbon credits or certified emission reductions, reducing the environmental impacts generated by the Competition.

The event will comply with ABNT ISO 20121 guidelines - Management Systems for Sustainable Events. Interactive educational actions were also planned, including energy generation through electrical flooring and available bicycles, recycling demonstrations and sustainable building processes, among others.

In the skill workshops, an expert will monitor and ensure proper waste disposal during the competitions and provide other sustainability guidelines. In other Anhembi Park areas, there will also be selective waste collection, with two different types of bins: recyclable (paper, plastic, tetrapak packages, among others) and non-recyclables (napkins, Styrofoam, food scraps, aluminum foil).

4. WHO'S WHO?

4.1 WorldSkills São Paulo 2015 Executive Committee

Frederico Lamego - CEO

Oswaldo Borges - Deputy CEO

Gustavo Rosa - Development Manager

Gustavo Leal - SENAI Operations Director

Rafael Lucchesi - SENAI General Director

Marcos Gamboa - Operations Manager

Paulo Colaço - Financial Manager



Efficiency, easy to use and first-class quality, besides the range and color matching for solid colors, metallic and pearls which enable an exceptional finish. The excellent Glasurit reputation is the recognition of the market to provide high quality products and services, such as the water-based line 90 and the high solid line 55.

4.2 WorldSkills International Board of Directors

Simon Bartley (UK) - President

Jos de Goey (NL) - Vice President for Strategic Affairs

Stefan Praschl (AT) - Vice President for Technical Affairs

Roberto Spada (BR) - Vice President for Special Affairs

San-Quei Lin (TW) - Vice Chair of the Strategy Committee

Michael Fung (HK) - Vice Chair of the Technical Committee

Terry Cooke (CA) - Treasurer

Rafael Lucchesi (BR) - Ex Officio WorldSkills São Paulo 2015

Ali Al Marzouqi (AE) - Ex Officio WorldSkills Abu Dhabi 2017



Take a new look at skills with Autodesk

Imagine, design, and create a better world with help from Autodesk Education. Students and Educators get free* access to the software used to make the games, movies, buildings, and products of the future.

Autodesk is a world leader in 3D design, engineering, and entertainment software for manufacturing, building and construction, and media and entertainment.

www.autodesk.com/education

*Free Autodesk software and/or cloud-based services are subject to acceptance of and compliance with the terms and conditions of the software license agreement or terms of service that accompany such software or cloud-based services. Software and cloud-based services provided without charge to Education Community members may be used solely for purposes directly related to learning, teaching, training, research or development and shall not be used for commercial, professional or any other for-profit purposes.

4.3 Worldskills Secretariat

<i>David Hoey</i>	<i>WorldSkills International</i>	<i>Chief Executive Officer</i>
<i>Sarah Rogers</i>		<i>Executive Assistant to the CEO</i>
<i>Katherine Pilcher</i>		<i>Finance and Logistics Manager</i>
<i>Michelle Bussey</i>		<i>Communications, Marketing, and Special Events Director</i>
<i>Laura London</i>		<i>Communications Manager</i>
<i>Alex Musial</i>		<i>Conference and Projects Manager</i>
<i>Jane Stokie</i>		<i>Technical Director</i>
<i>Luise Kühnel</i>		<i>Technical Assistant</i>
<i>Alexander Amiri</i>		<i>Sponsorship and Partnership Director</i>
<i>John Cox</i>		<i>Information Systems Senior Manager</i>
<i>Adam Walsh</i>		<i>Senior Software Developer</i>
<i>Joni Aaltonen</i>		<i>Senior Web Developer</i>
<i>Fabian Vogler</i>		<i>Digital Media Developer</i>
<i>Ellen Coppens</i>		<i>Member Services Liaison</i>
<i>Sean Kearney</i>		<i>WorldSkills Foundation</i>
<i>Grace Lung</i>	<i>Project Developer</i>	
<i>Nuria Portland</i>	<i>Secretary</i>	

4.4 Participating WorldSkills Member countries and regions

ISO Abbreviation		Country or Region	ISO Abbreviation		Country or Region
1	AE	United Arab Emirates	25	HK	Hong Kong, China
2	AM	Armenia	26	HU	Hungary
3	AR	Argentina	27	ID	Indonesia
4	AT	Austria	28	IE	Ireland
5	AU	Australia	29	IL	Israel
6	BE	Belgium	30	IN	India
7	BH	Kingdom of Bahrain	31	IR	Iran
8	BR	Brazil	32	IT	South Tyrol, Italy
9	BY	Belarus	33	JM	Jamaica
10	CA	Canada	34	JP	Japan
11	CH	Switzerland	35	KR	Korea
12	CL	Chile	36	KW	Kuwait
13	CN	China	37	KZ	Kazakhstan
14	CO	Colombia	38	LI	Principality of Liechtenstein
15	CR	Costa Rica	39	LU	Luxembourg
16	DE	Germany	40	LV	Latvia
17	DK	Denmark	41	MA	Morocco
18	DO	Dominican Republic	42	MN	Mongolia
19	EC	Ecuador	43	MO	Macao, China
20	EE	Estonia	44	MX	Mexico
21	ES	Spain	45	MY	Malaysia
22	FI	Finland	46	NA	Namibia
23	FR	France	47	NL	Netherlands
24	GE	Georgia	48	NO	Norway

ISO Abbreviation		Country or Region	ISO Abbreviation		Country or Region
49	NZ	<i>New Zealand</i>	57	TH	<i>Thailand</i>
50	OM	<i>Oman</i>	58	TR	<i>Turkey</i>
51	PT	<i>Portugal</i>	59	TW	<i>Chinese Taipei</i>
52	PY	<i>Paraguay</i>	60	UK	<i>United Kingdom</i>
53	RU	<i>Russia</i>	61	US	<i>United States of America</i>
54	SA	<i>Saudi Arabia</i>	62	VN	<i>Vietnam</i>
55	SE	<i>Sweden</i>	63	ZA	<i>South Africa</i>
56	SG	<i>Singapore</i>	64	ZM	<i>Zambia</i>

4.5 Skill Management Teams

	<i>Skill</i>	<i>Jury President</i>	<i>Chief Expert and Deputy Chief Expert</i>
1	<i>Polymechanics and Automation</i>	<i>Maura Corporán DO</i>	<i>Torsten Wolf DE Sherman Mukoyama BR</i>
2	<i>Information Network Cabling</i>	<i>Simon Tang HK Vai Keong Kong MO</i>	<i>Takuo Kikuchi JP Joakim Carlsson SE</i>
3	<i>Manufacturing Team Challenge</i>	<i>Hilal AlAmri OM Khalid AlMazrouei KW</i>	<i>Mika Junttila FI Marc Rousseau FR</i>
4	<i>Mechatronics</i>	<i>Pontus Slättman SE</i>	<i>Michael Linn DE Hermann Studnitzka AT</i>
5	<i>Mechanical Engineering Design – CAD</i>	<i>Jose Luis Leitão BR</i>	<i>Dário Pinto PT Matthew Bell UK</i>
6	<i>CNC Turning</i>	<i>Inta Ane LV</i>	<i>Gernoth Dolinar AT William Brunie FR</i>
7	<i>CNC Milling</i>	<i>Rico Cioccarelli CH Xavier Mendieta EC</i>	<i>Ian Thompson UK Daniel De Aviz BR</i>
8	<i>Architectural Stonemasonry</i>	<i>Mohammed Murtadha Al Farabi BH</i>	<i>Bernhard Hasenöhl</i>
9	<i>IT Software Solutions for Business</i>	<i>Nadine Leachman JM Lilit Petrosyan AM</i>	<i>Monde Woo HK Bong Win Ce ID</i>

10	Welding	Byung Ha Kang KR	Paul Condran AU Bovornchok Poopat TH
11	Print Media Technology	Saleh Alsenedi SA Antonio De Carolis LU	Vesa Iltola FI Douglas Moura BR
12	Wall and Floor Tiling	Alina Fleaca BE	Roger Dähler CH David McCay UK
13	Autobody Repair	Yesid Rusinque CO Salomón Ceballos Ochoa MX	Kjell Arild Orheim NO Jesper Vang Falkenberg DK
14	Aircraft Maintenance	John Twohig IE, Yehuda Calo Livne IL	Richard Johnstone CA Seppo Huittinen FI
15	Plumbing and Heating	Nguyen Chi Truong VN	Markus Niederer CH Paul Dodds UK
16	Electronics	Iris Seet SG Sens Shoolongo NA	Ray Coyle UK Stéphane Balet CH
17	Web Design	Simon Tang HK Vai Keong Kong MO	Jeff Boulton CA Jarrad Langdon AU
18	Electrical Installations	Claudia Contreras Gálvez CL Akira Kakimoto JP	Per Svensson SE Luke Boustridge NZ
19	Industrial Control	Ghalip Spahat MY	Andreas Puchner AT Peter Friesen CA
20	Bricklaying	Kanisery Venugopalan IN	Troy Everett AU Mike Burdett UK
21	Plastering and Drywall Systems	Thomas Pardeller IT Francis Mwape ZM	Peter Moore UK Atisha Lutchman ZA
22	Painting and Decorating	Scott Norman US	Peter Walters UK Ian Vickery AU
23	Mobile Robotics	Malcolm Whinham NZ Fang Yuan CN	Anton van den Brink NL Paulo Villiger BR
24	Cabinetmaking	Peter van den Berg NL	Jason Hindes AU Robert Tobias US
25	Joinery	Timea Daroczi HU	José Fonséca FR Ricardo Arnau WS
26	Carpentry	Jose Leitão BR Armando Carvalho PT	Pat Phillips UK Adrian Wenger CH
27	Jewellery	John Twohig IE Maureen Evans-Olsen UK	Anthony Constantino PT Ragnvald Nore NO

	<i>Skill</i>	<i>Jury President</i>	<i>Chief Expert and Deputy Chief Expert</i>
28	<i>Floristry</i>	<i>Marco Frick LI Francis Mwape ZM</i>	<i>Alan Randell-Smith AU Nina Stanley NZ</i>
29	<i>Hairdressing</i>	<i>Elisabeth Lange NO Ulan Zharmukhamedov KZ</i>	<i>Donna De Maria AU Katri Pokkinen FI</i>
30	<i>Beauty Therapy</i>	<i>André Vermeulen ZA</i>	<i>Sue Simpson UK Valérie Germani FR</i>
31	<i>Fashion Technology</i>	<i>Nadine Leachman JM Lilit Petrosyan AM</i>	<i>Victoria Chan MO Donna Drain AU</i>
32	<i>Pâtisserie</i>	<i>Brigitte Collins AU</i>	<i>Elisabeth Novaes BR Emmanuel Lecanu FR</i>
33	<i>Automobile Technology</i>	<i>Yesid Rusinque CO Salomón Ceballos Ochoa MX</i>	<i>Grant Petch AU Michel J. Tinguely CH</i>
34	<i>Cooking</i>	<i>Karine Raymond CA Sarnai Batchuluun MN</i>	<i>Svein Magnus Gjørvik NO Stephen Pope NZ</i>
35	<i>Restaurant Service</i>	<i>Vacharapong Mukcherd TH</i>	<i>Rudolf Wolfschluckner AT Ray Cullen IE</i>
36	<i>Car Painting</i>	<i>Ali Al Marzouqi AE</i>	<i>Rodney Bolton US Jens Søndergaard Hansen D</i>
37	<i>Landscape Gardening</i>	<i>Pavel Chernykh RU Archil Barbakadze GE</i>	<i>Simon Hugi CH Raili Laas EE</i>
38	<i>Refrigeration and Air Conditioning</i>	<i>Tõnis Arvisto EE Dyah Kartiningdyah ID</i>	<i>Karsten Beerman DE Chris Macdonald AU</i>
39	<i>IT Network Systems Administration</i>	<i>Hannu Immonen FI Ming Shan Chen TW</i>	<i>Anders Lantz SE Doug Warden CA</i>
40	<i>Graphic Design Technology</i>	<i>Saleh Alsenedi SA Antonio de Carolis LU</i>	<i>Thierry Herman BE Sarah Jones AU</i>
41	<i>Health and Social Care</i>	<i>Eleno Agapito Bron Gonzalez PY Maylen Brenes Jimenez CR</i>	<i>Sabina Decurtins CH Christoph Vigil IT</i>
42	<i>Construction Metal Work</i>	<i>Franz Schropp DE Erhan Girit TR</i>	<i>Roger Müller CH Tim O'Halloran IE</i>
43	<i>Plastic Die Engineering</i>	<i>Pia Hegner DK</i>	<i>Mallinathan Puthukkudi IN Yung Chang Hsu TW</i>
44	<i>Visual Merchandising and Window Dressing</i>	<i>Marco Frick LI Olga Dekhtiarenko BY</i>	<i>Erika Scharff NL Tat Keung Chan HK</i>
45	<i>Prototype Modelling</i>	<i>Halim El Hallam MA</i>	<i>Rainer Honegger CH Agung Satriawan ID</i>

	<i>Skill</i>	<i>Jury President</i>	<i>Chief Expert and Deputy Chief Expert</i>
46	<i>Sheet Metal Technology</i>	<i>Zhaleh Omrani IR</i>	<i>Frédéric Gil FR Hilton Jones AU</i>
D1	<i>Concrete Construction Work</i>	<i>Pavel Chernykh RU Archil Barbakadze GE</i>	<i>Thomas Prigl AT Wah ik Alexan SE</i>
D2	<i>Bakery</i>	<i>Thibault Dubus FR</i>	<i>Urs Roethlin CH Ashley Schmidt AU</i>
D3	<i>Industrial Mechanics Millwright</i>	<i>Fernando Callegari AR Soledad Iglesias ES</i>	<i>Craig Brazil CA Peter Buttenshaw AU</i>
D4	<i>Heavy Vehicle Maintenance</i>	<i>Thomas Pardeller IT Olga Dekhtiarenko BY</i>	<i>Bobby Haraba CA Werner Seltenhammer AT</i>

QUALIDADE E PRODUTIVIDADE COM SOLUÇÕES DE ALTA TECNOLOGIA

*Quality and Productivity With
High Technology Solutions*



Mitutoyo
Soluções em Metrologia

5. SPECIAL THANKS

5.1 To the Volunteers

Our extra special thanks go to the 800 volunteers who chose to donate their time, efforts, and talent for more than a week to ensure that all of the participants and visitors are cared for and receive the necessary support.

Saying “thank you” is not enough to express the joy and satisfaction we feel to have them helping us throughout the event. After all, it is a 212,000 m² area with approximately 200,000 visitors, and this great experience will only be possible with help from so many volunteers.

WorldSkills São Paulo 2015 volunteers chose the mission of contributing to the development of vocational education in Brazil and the world. In practical terms, this is represented through the support they provide to Competitors from all Delegations, helping with language differences in order to not hinder communication; organizing photos and videos; helping to guide the flow of people in the restaurants; and helping to conduct public visits and support activities in the skill Competitions.

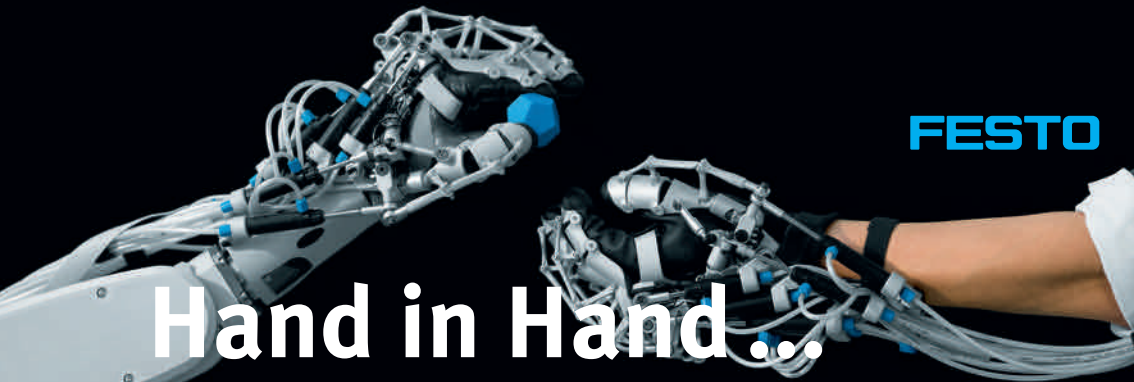

Hand in Hand...

... the future begins with ideas. And ideas begin at Festo. World-class solutions in Automation and Didactic worldwide:

→ www.festo.com/didactic

The goal is to have a volunteer available whenever someone needs help. All volunteers are aware that volunteering is the best way both to help others and to help themselves. Volunteering is a great learning experience, a fulfilling way to spend time, and a clear example of social responsibility.

We are sure that the participation certificates delivered to our volunteers will be more than celebrated, because besides being an integral part of the event, volunteers know that they perform an amazing and valuable job!

With Bosch you are assured

www.minhavidacombosch.com.br



BOSCH
Tecnologia para a vida

5.2 To Partners

WorldSkills São Paulo 2015 is pleased to collaborate with major partners for the 43rd WorldSkills Competition, the greatest vocational education and skills excellence Competition in the world, held in Latin America for the first time. The Competition was made possible by a strong partnership between the National Service for Industrial Training (SENAI) and WorldSkills International, and both entities sincerely thank all of you for your attention and support as co-organizers, partners, and sponsors.

We would like to begin by thanking our co-organizer partner from the Industry System, SESI (Industrial Social Service), for collaborating in organizing the Competition, not only financially but also by providing expertise and sharing skilled labour with SENAI.

Other essential partners helping to build the select team of Competition Organizer employees were the 27 regional SENAI divisions, which provided the Workshop Managers and Workshop Sector Managers for all of the skills, and supported us with employees for the technical and service departments.

We would also like to thank our government and institutional partners. Our partnership with all three-government levels and especially with the Ministry of Education, the Chief of Staff Office (Casa Civil), and the International and Federative Affairs Department in São Paulo was essential to connect with strategic stakeholders and make this Competition feasible. Conselho do SESI, Sebrae (Brazilian Micro and Small Business Support Service), and SENAC (National Service for Industrial Training) are institutional partners that work together to coordinate actions that promote Brazilian Vocational education.

Special thanks to our national and international sponsors. Support from these companies made the Competition and side events possible and added expertise, perspective, and innovation to all we experienced.

Thanks to all of these well-orchestrated commitments. We are proud to launch WorldSkills São Paulo 2015, believing in the success of this week dedicated to promoting Vocational Skills Education!

5.3 To WorldSkills São Paulo 2015 Sponsors and Global Partners

WorldSkills International and WorldSkills São Paulo 2015 are honoured to receive support from the WorldSkills Global Partners.

We thank Samsung (the Overall Event Presenter), Stanley Black & Decker, 3M, AWS (American Welding Society), Autodesk, Cisco, Festo, Fluke, Lincoln Electric, Saint-Gobain, and Siemens.

As Global Partners, these renowned companies are already individually involved in education and training initiatives in various markets around the world.

Associating these organizations with the WorldSkills mission is gratifying, and it is certainly very important in making the WorldSkills Competition possible. Surely, this contribution adds value to all stakeholders involved, as it provides an opportunity for entities to talk directly to each other, adopt best practices to promote education, encourage vocational skills education globally, and increase skilled labour in industry.

At the same time, the Competition gives these partners the opportunity to develop avenues of collaboration that sustain the success of the Competition and ensure we realize our vision.

Besides Global Partners, it is also very important to highlight the presence and interest of participating Brazilian and international companies.

The support and contribution that these organizations and institutions provide will significantly affect the skill competitions, the tools used by Competitors, and the specific services available to make the Competition possible.

These partnerships encourage our collective success.

www.vw.com.br/premios

We innovate in every area, but we stay true to our traditions in one thing: awards.



Use your smartphone's QR code reader and learn more about the awards earned by Volkswagen.

For those who know and love cars, Volkswagen is The Car.



Das Auto.

Together we can make traffic better. Awards: Revista Quatro Rodas - The Selected 2014, Grand Winner - Golf (October 2014); Car and Driver - Top Pick 2014 - cars costing up to R\$31 thousand - take up! (June 2014); Jornal do Carro - Brazil's Best 2014 - Medium-sized Hatches costing up to R\$70 thousand - Golf (8/27/2014); Motor Show - Purchase of the Year 2015 - Medium-sized Hatches - Golf (January and February 2015); Abiauto - Best Pick-up Truck 2014 - Saveiro; Agência Autoinforme - Best Resale Value 2014 - Medium-sized Hatches - Golf; Autoesporte - Car of the Year 2014 - Golf (January 2014); Best Cars - Brazil's Best Hatch 2015 - Golf (May 2015); Autoesporte - Best Buy 2015 - Top pick in its segment - Medium-sized Hatches - Golf (May 2015).

6. GENERAL TRAVEL INFORMATION

Luggage

Please check with your airline about the exact weight allowed. Please mark your luggage with your first and last name and contact details, which must be legible.

Currency exchange

The official currency in Brazil is the Brazilian Real (BRL). In order to access the updated exchange rates, please refer to the Central Bank of Brazil website: www4.bcb.gov.br/pec/taxas/ingl/ptaxnpsq.asp?id=quotations

The international airport in São Paulo (GRU) has several currency exchange bureaus open 24 hours.

Safety for Arrival and Departure at Airports:

- *Always keep your belongings and important documents in hand.*
- *Only ask Police Officers or identified employees for information or assistance.*
- *If you need to exchange foreign currency, search for an accredited currency exchange bureau.*
- *Preferably, only use official and authorized taxis at the airports, and place your luggage in the trunk yourself.*
- *Pay close attention when using ATMs, and do not accept help from people you do not know.*
- *Keep your passport in the safe deposit box at the hotel, but always carry a document with a photo when going around the city.*



www.worldskillssaopaulo2015.com

Official sponsor



www.scmtecmatic.com.br

Transportation

Bus

The entire metropolitan region of São Paulo has public bus lines operating. For their itineraries and schedules, please check www.sptrans.com.br.

Fare: BRL 3.50

Subway

There is a 75.5 km subway network, distributed into five lines, connected by 63 stations.

Operating hours: from 04:40 to 24:00.

On Saturdays, the subway operates until 01:00.

Fare: BRL 3.50

Map: www.metro.sp.gov.br/pdf/mapa-da-rede-metro.pdf

Taxi

São Paulo has a fleet of over 33,000 official taxis – white cars identified appropriately.

Initial rate: BRL 4.50 – with an additional fee per kilometre. From 06:00 to 20:00,

Friday-Monday, it costs BRL 2.75 per kilometre; at other times of the day, this amount increases to BRL 3.45 per kilometre.

Weather

The weather in São Paulo is considered humid subtropical with less rain in the winter and an annual average temperature of 19.8 ° Celsius. August is still winter in Brazil with an average 17.1 ° Celsius.

Business hours

Generally, business hours are 09:00-18:00 Monday-Saturday. Banks operate 10:00-16:00 from Monday-Friday. Malls are open from Monday-Saturday 10:00-22:00, and 14:00-20:00 on Sundays and official holidays.

Publishing information

Graphic Design: LOWFAT

Content: WorldSkills São Paulo 2015 Competition Organizer



WorldSkills São Paulo 2015 will have two types of garbage collectors:
RECYCLABLE (paper, plastic, tetrapak and other materials);

NON-RECYCLABLE (WASTE): (napkins, Styrofoam, food scraps, aluminum foil).
Participate! Choose Sustainability!

Patrocinador Master | Master Sponsor



Patrocinador Ouro | Gold Sponsor



Patrocinador Prata | Silver Sponsor



Patrocinador Bronze | Bronze Sponsor



Parceiros Institucionais | Institutional Partners

